

Chapter 4 Transients

Chapter 4 Transients

1. Solve first-order RC or RL circuits.
2. Understand the concepts of transient response and steady-state response.

3. Relate the transient response of first-order circuits to the time constant.
4. Solve *RLC* circuits in dc steady-state conditions.
5. Solve second-order circuits.
6. Relate the step response of a second-order system to its natural frequency and damping ratio.

Transients

The time-varying currents and voltages resulting from the sudden application of sources, usually due to switching, are called **transients**. By writing circuit equations, we obtain integrodifferential equations.

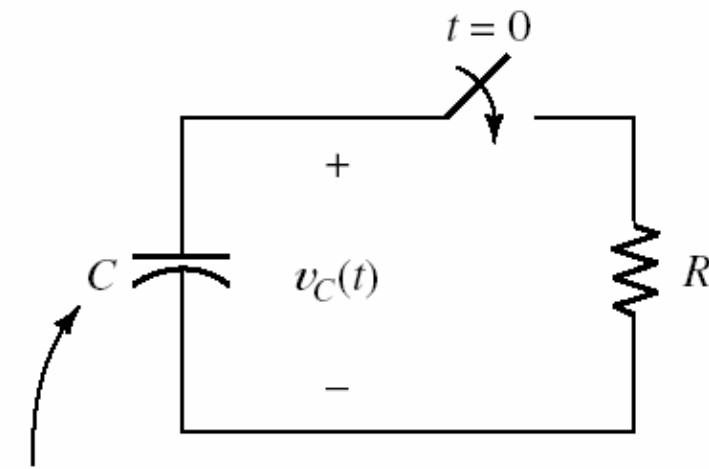

Capacitance charged to V_i
prior to $t = 0$

(a) Electrical circuit

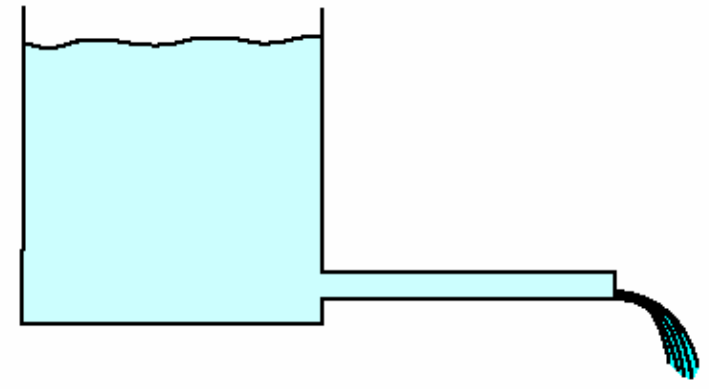

(b) Fluid-flow analogy: a filled water tank
discharging through a small pipe

Figure 4.1 A capacitance discharging through a resistance and its fluid-flow analogy. The capacitor is charged to V_i prior to $t = 0$ (by circuitry that is not shown). At $t = 0$, the switch closes and the capacitor discharges through the resistor.

Discharge of a Capacitance through a Resistance

$$C \frac{dv_C(t)}{dt} + \frac{v_C(t)}{R} = 0 \qquad v_C(t) = Ke^{st}$$

$$RC \frac{dv_C(t)}{dt} + v_C(t) = 0 \qquad RCKse^{st} + Ke^{st} = 0$$

$$s = \frac{-1}{RC}$$

$$v_C(0+) = V_i$$

$$v_C(t) = Ke^{-t/RC}$$

$$v_C(t) = V_i e^{-t/RC}$$

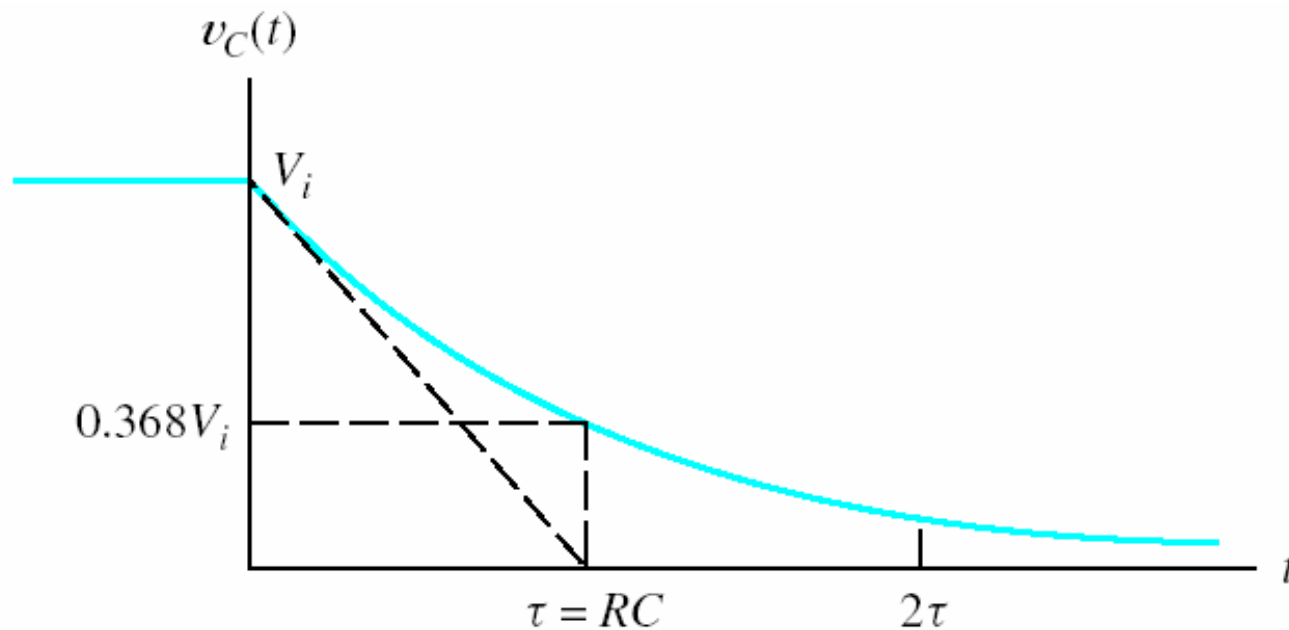
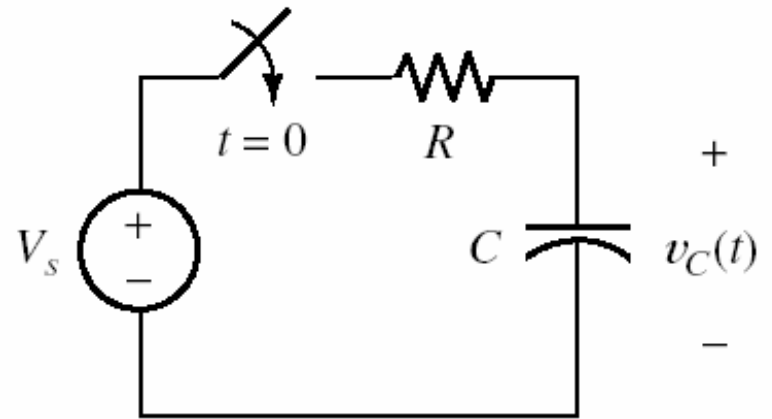

Figure 4.2 Voltage versus time for the circuit of Figure 4.1(a). When the switch is closed, the voltage across the capacitor decays exponentially to zero. At one time constant, the voltage is equal to 36.8 percent of its initial value.

The time interval $\tau = RC$ is called the time constant of the circuit.

$$v_C(t) = V_s - V_s e^{-t/\tau}$$

Figure 4.3 Capacitance charging through a resistance. The switch closes at $t = 0$, connecting the dc source V_s to the circuit.



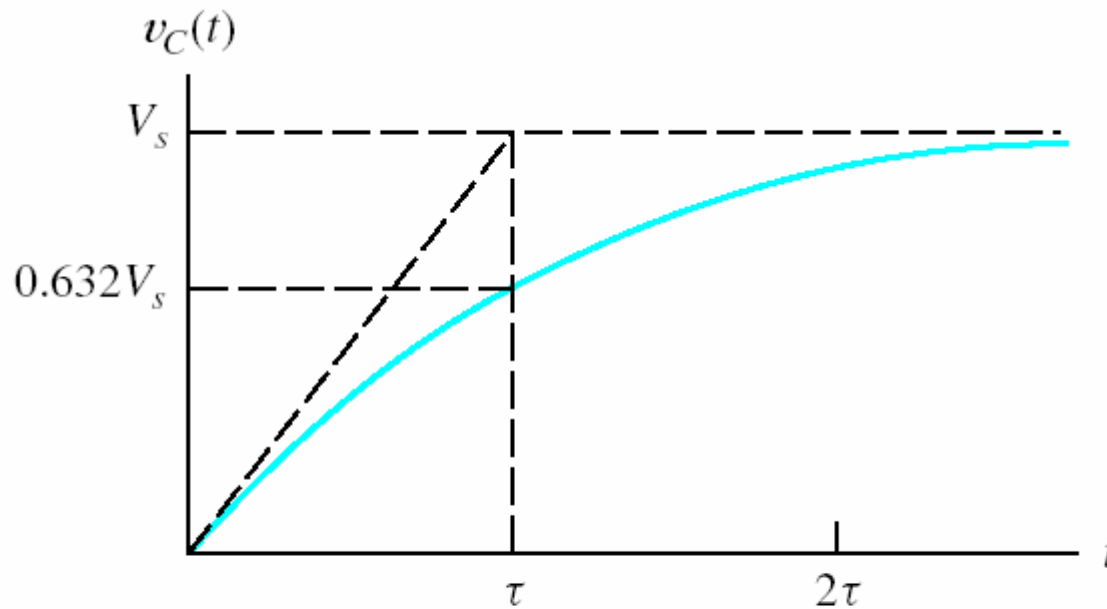

Figure 4.4 The charging transient for the RC circuit of Figure 4.3.

(Refer to p.151 and p.152.)

DC STEADY STATE

The steps in determining the forced response for *RLC* circuits with dc sources are:

1. Replace capacitances with open circuits.
2. Replace inductances with short circuits.
3. Solve the remaining circuit.

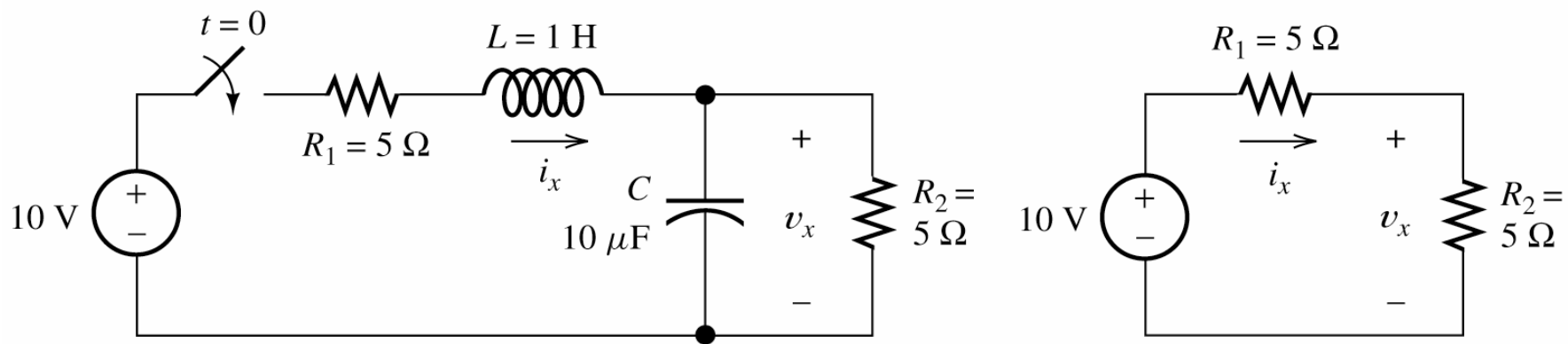

(a) Original circuit

(b) Equivalent circuit for steady state

Figure 4.5 The circuit and its dc steady-state equivalent for Example 4.1.

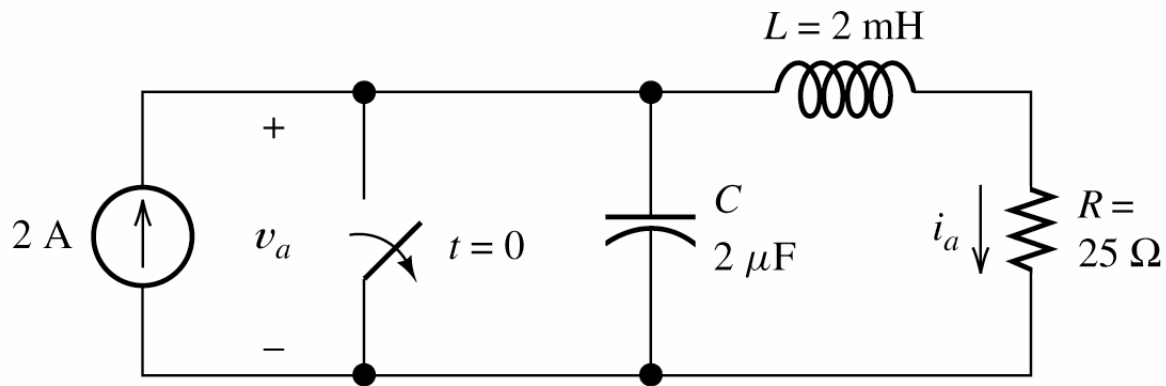

(a)

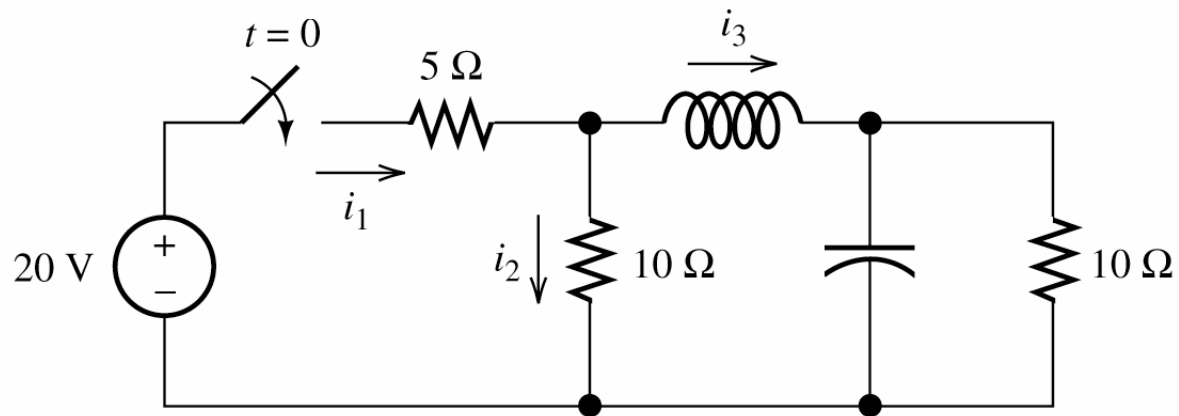

(b)

Figure 4.6 Circuits for Exercise 4.3.

***RL* CIRCUITS**

The steps involved in solving simple circuits containing dc sources, resistances, and one energy-storage element (inductance or capacitance) are:

1. Apply Kirchhoff's current and voltage laws to write the circuit equation.
2. If the equation contains integrals, differentiate each term in the equation to produce a pure differential equation.
3. Assume a solution of the form $K_1 + K_2 e^{st}$.

- 4.** Substitute the solution into the differential equation to determine the values of K_1 and s . (Alternatively, we can determine K_1 by solving the circuit in steady state as discussed in Section 4.2.)
- 5.** Use the initial conditions to determine the value of K_2 .
- 6.** Write the final solution.

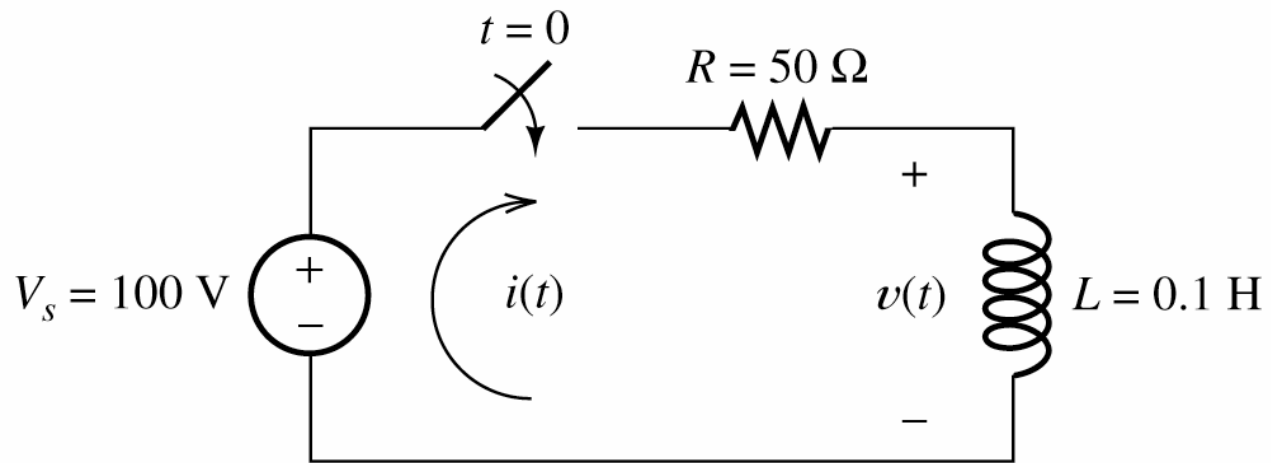
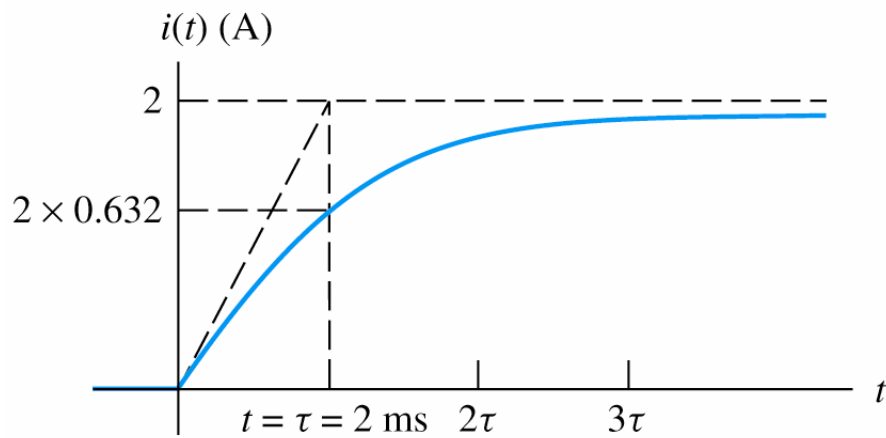
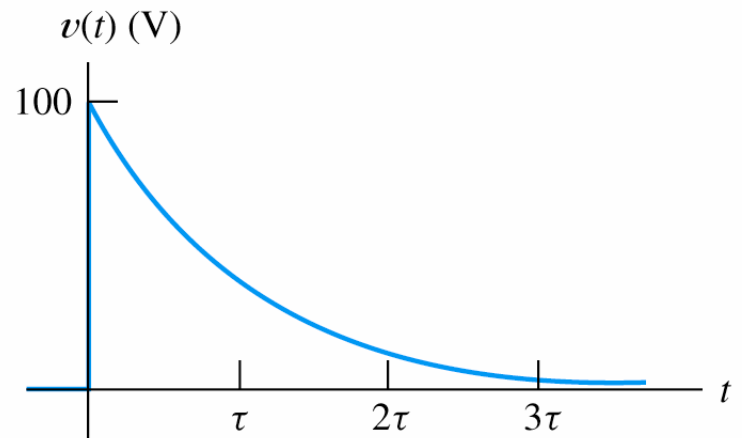

Figure 4.7 The circuit analyzed in Example 4.2.



(a)



(b)

Figure 4.8 Current and voltage versus time for the circuit of Figure 4.7.

RL Transient Analysis

$$i(t) = 2 + K_2 e^{-tR/L}$$

Time constant is

$$\tau = \frac{L}{R}$$

$$i(t) = 2 - 2e^{-tR/L}$$

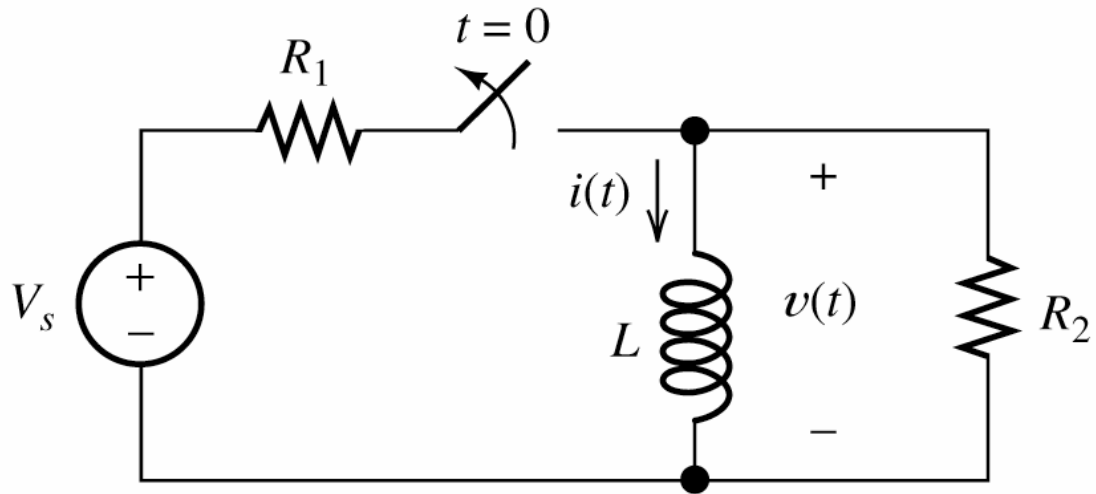

Figure 4.9 The circuit analyzed in Example 4.3.

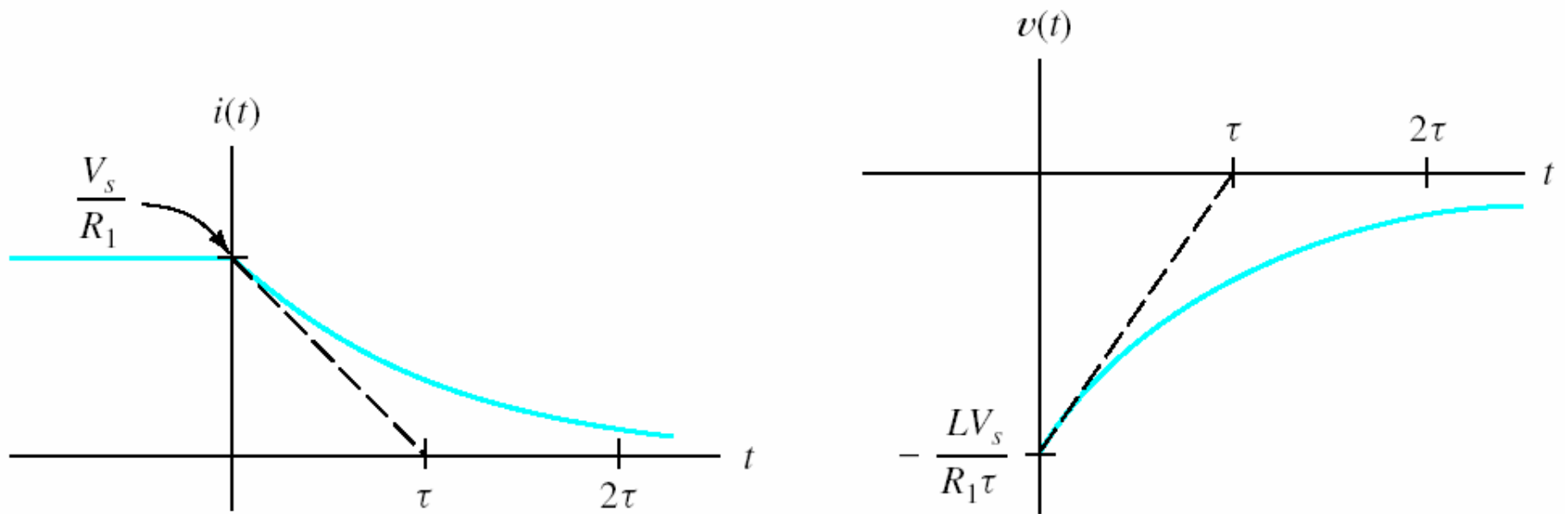

Figure 4.10 The current and voltage for the circuit of Figure 4.9.

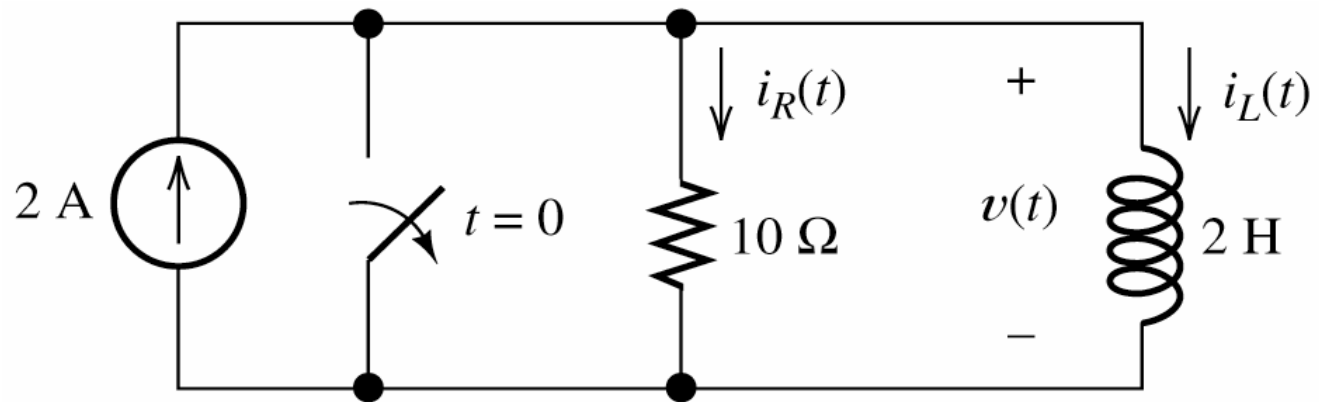

Figure 4.11 The circuit for Exercise 4.5.

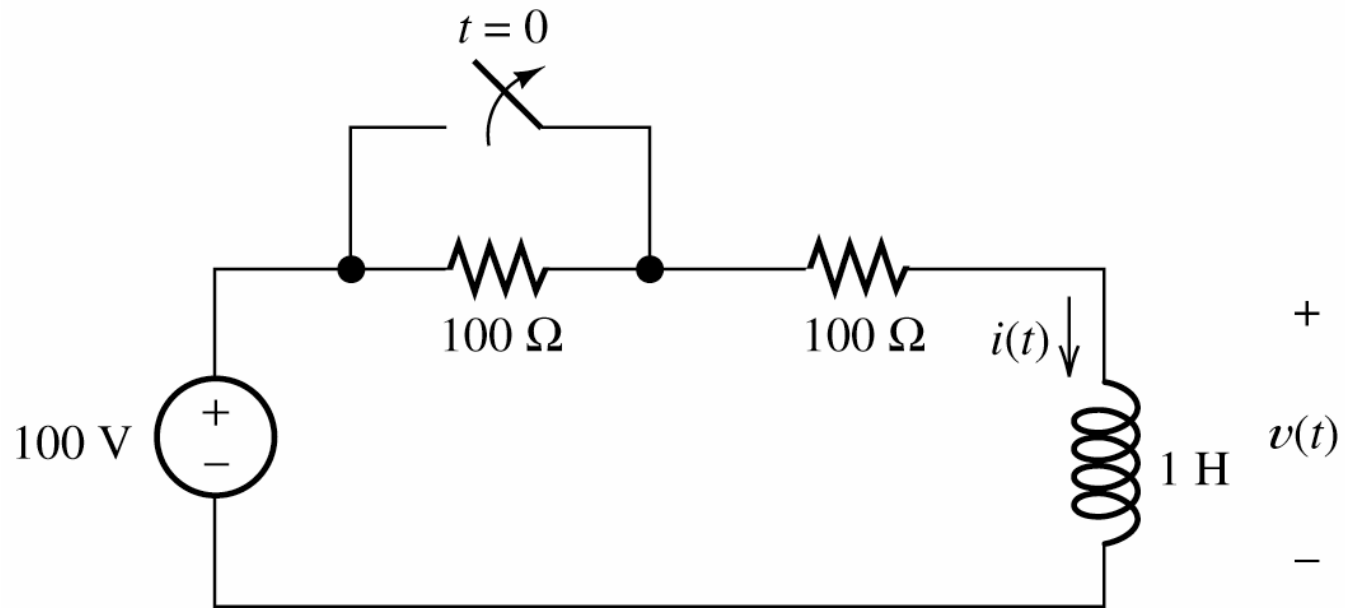

Figure 4.12 The circuit for Exercise 4.6.

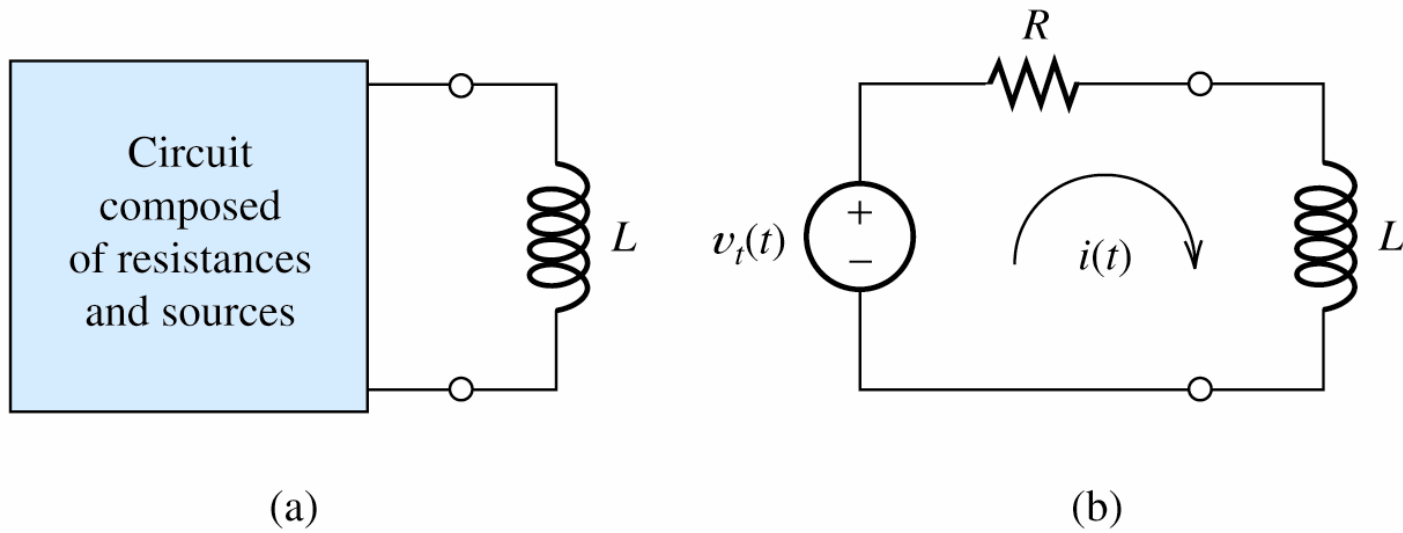

Figure 4.13 A circuit consisting of sources, resistances, and one inductance has an equivalent circuit consisting of a voltage source and a resistance in series with the inductance.

RC AND RL CIRCUITS WITH GENERAL SOURCES

The general solution consists of two parts.

The particular solution (also called the forced response) is any expression that satisfies the equation.

In order to have a solution that satisfies the initial conditions, we must add the complementary solution to the particular solution.

The homogeneous equation is obtained by setting the forcing function to zero.

The complementary solution (also called the natural response) is obtained by solving the homogeneous equation.

Step-by-Step Solution

Circuits containing a resistance, a source, and an inductance (or a capacitance)

1. Write the circuit equation and reduce it to a first-order differential equation.

2. Find a particular solution. The details of this step depend on the form of the forcing function. We illustrate several types of forcing functions in examples, exercises, and problems.

3. Obtain the complete solution by adding the particular solution to the complementary solution given by Equation 4.44, which contains the arbitrary constant K .

4. Use initial conditions to find the value of K .

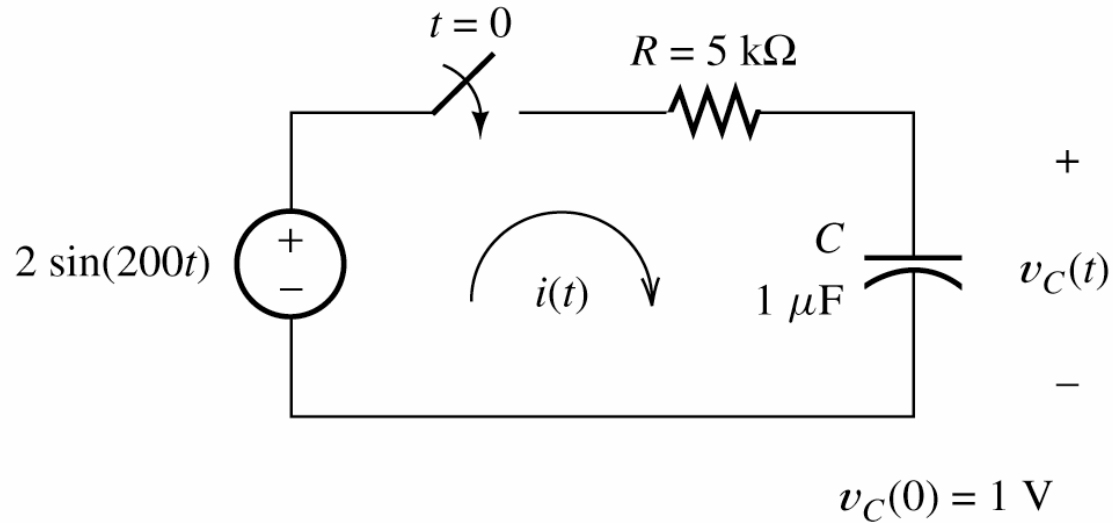

Figure 4.14 A first-order RC circuit with a sinusoidal source. See Example 4.4.

(Refer to equation (4.48))

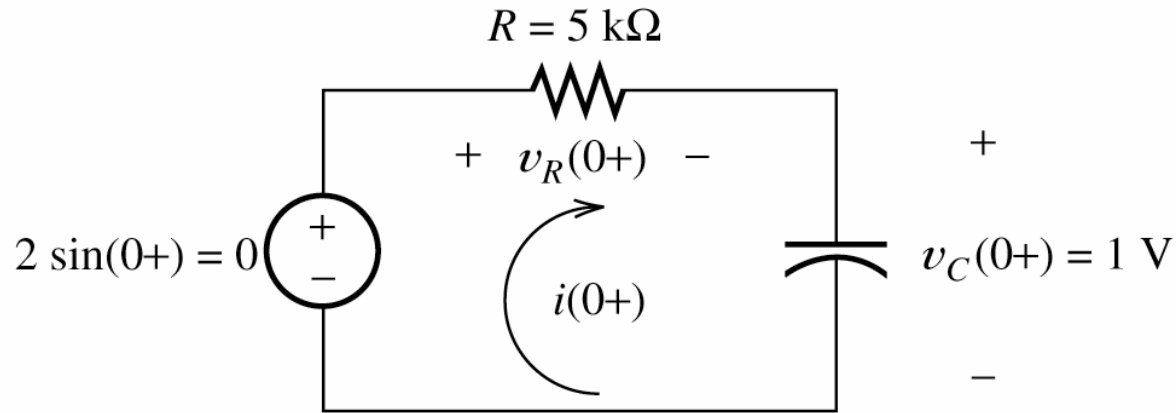

Figure 4.15 The voltages and currents for the circuit of Figure 4.14 immediately after the switch closes.

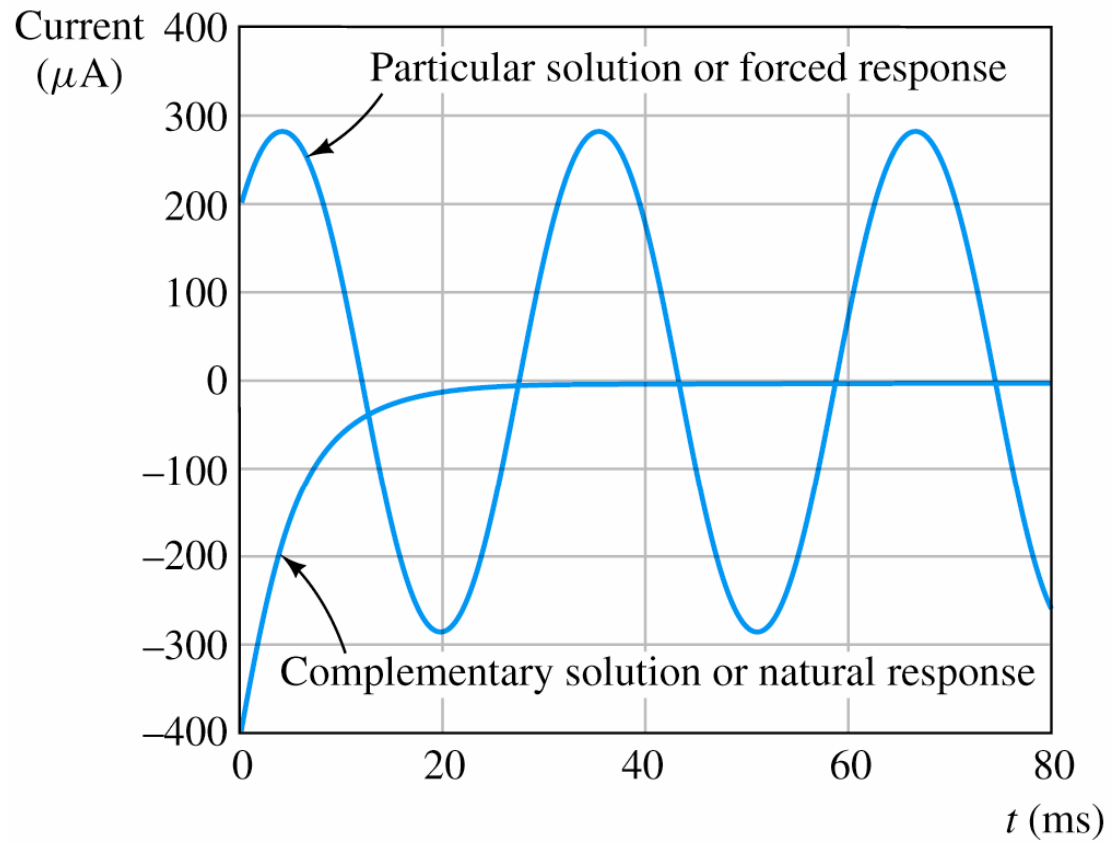

Figure 4.16 The complementary solution and the particular solution for Example 4.4.

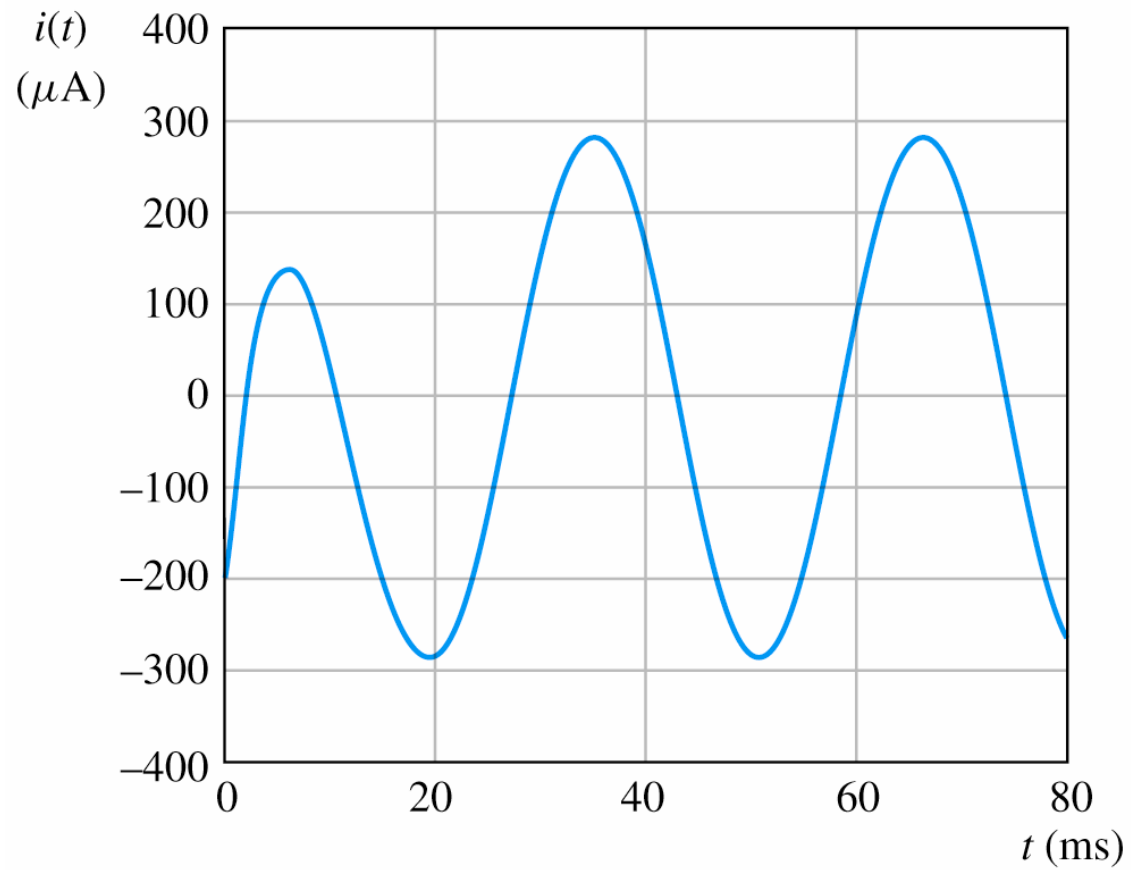

Figure 4.17 The complete solution for Example 4.4.

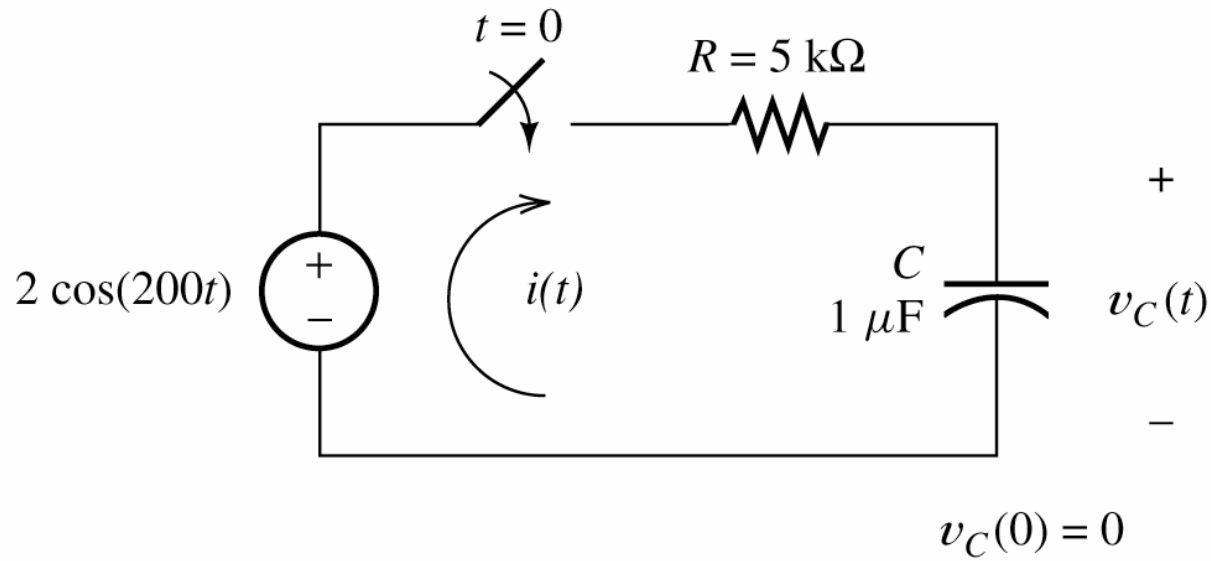

Figure 4.18 The circuit for Exercise 4.7.

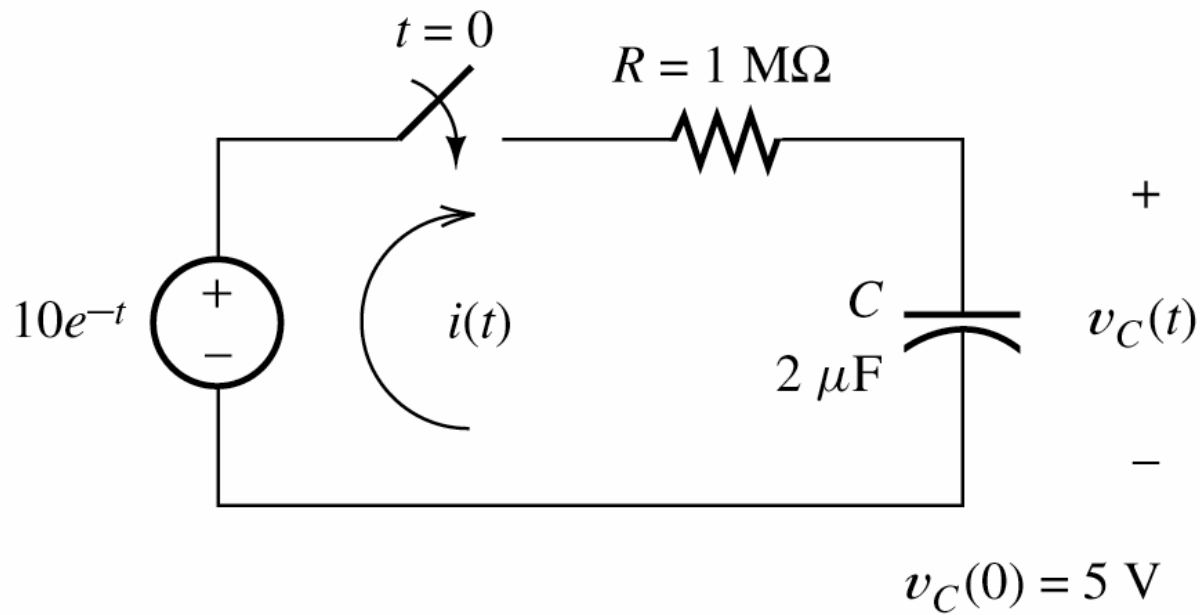
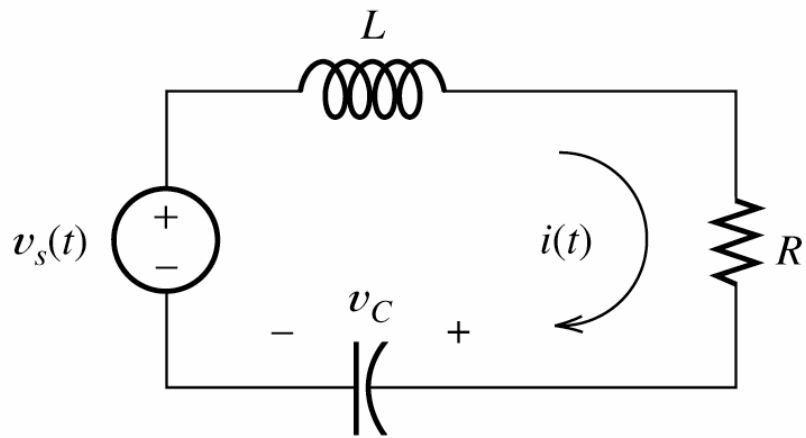
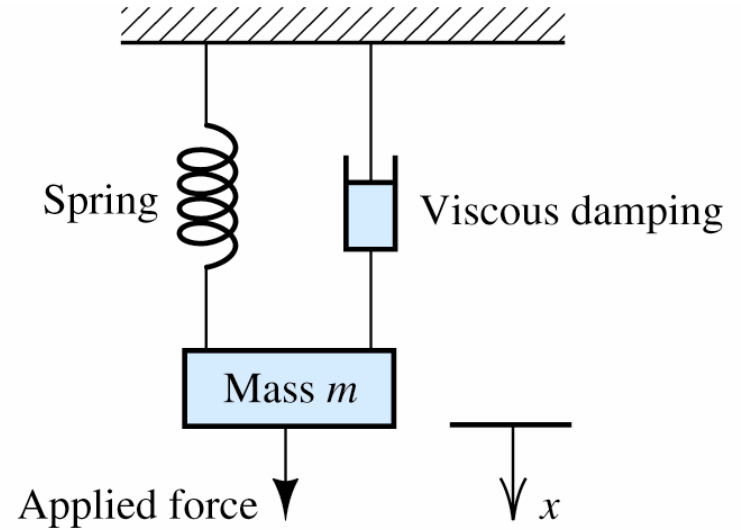

Figure 4.19 The circuit for Exercise 4.8.



(a) Electrical circuit



(b) Mechanical analog

Figure 4.20 The series RLC circuit and its mechanical analog.

SECOND-ORDER CIRCUITS

$$L \frac{di(t)}{dt} + Ri(t) + \frac{1}{C} \int_0^t i(t) dt + v_C(0) = v_s(t)$$

$$\alpha = \frac{R}{2L}$$

$$\omega_0 = \frac{1}{\sqrt{LC}}$$

Damping coefficient

Undamped resonant frequency

$$\frac{d^2 i(t)}{dt^2} + 2\alpha \frac{di(t)}{dt} + \omega_0^2 i(t) = f(t)$$

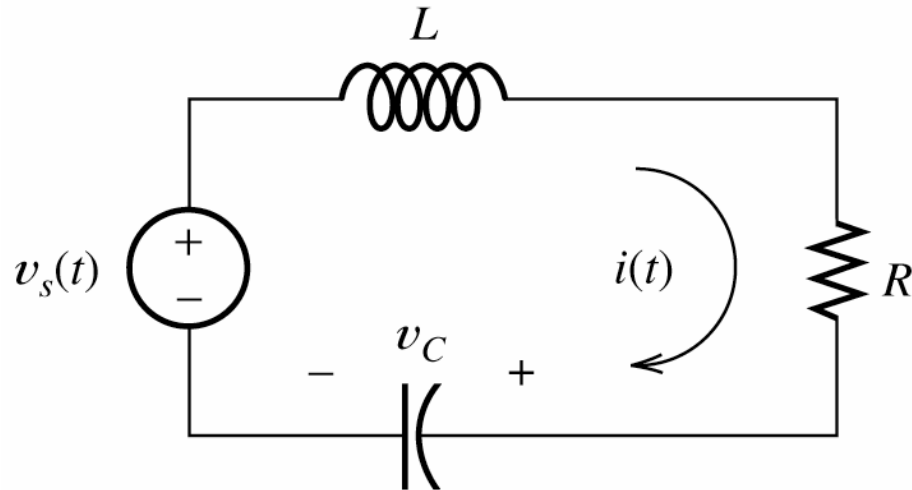

(a) Electrical circuit

$$\zeta = \frac{\alpha}{\omega_0}$$

$$s_1 = -\alpha + \sqrt{\alpha^2 - \omega_0^2}$$

$$s_2 = -\alpha - \sqrt{\alpha^2 - \omega_0^2}$$

1. *Overdamped case* ($\zeta > 1$). If $\zeta > 1$ (or equivalently, if $\alpha > \omega_0$), the roots of the characteristic equation are real and distinct. Then the complementary solution is

$$x_c(t) = K_1 e^{s_1 t} + K_2 e^{s_2 t}$$

In this case, we say that the circuit is **overdamped**.

2. Critically damped case ($\zeta = 1$). If $\zeta = 1$ (or equivalently, if $\alpha = \omega_0$), the roots are real and equal. Then the complementary solution is

$$x_c(t) = K_1 e^{s_1 t} + K_2 t e^{s_1 t}$$

In this case, we say that the circuit is **critically damped**.

3. Underdamped case ($\zeta < 1$). Finally, if $\zeta < 1$ (or equivalently, if $\alpha < \omega_0$), the roots are complex. (By the term *complex*, we mean that the roots involve the square root of -1 .) In other words, the roots are of the form

$$s_1 = -\alpha + j\omega_n \text{ and } s_2 = -\alpha - j\omega_n$$

in which j is the square root of -1 and the **natural frequency** is given by

$$\omega_n = \sqrt{\omega_0^2 - \alpha^2}$$

In electrical engineering, we use j rather than i to stand for square root of -1, because we use i for current.

For complex roots, the complementary solution is of the form

$$x_c(t) = K_1 e^{-\alpha t} \cos(\omega_n t) + K_2 e^{-\alpha t} \sin(\omega_n t)$$

In this case, we say that the circuit is **underdamped**.

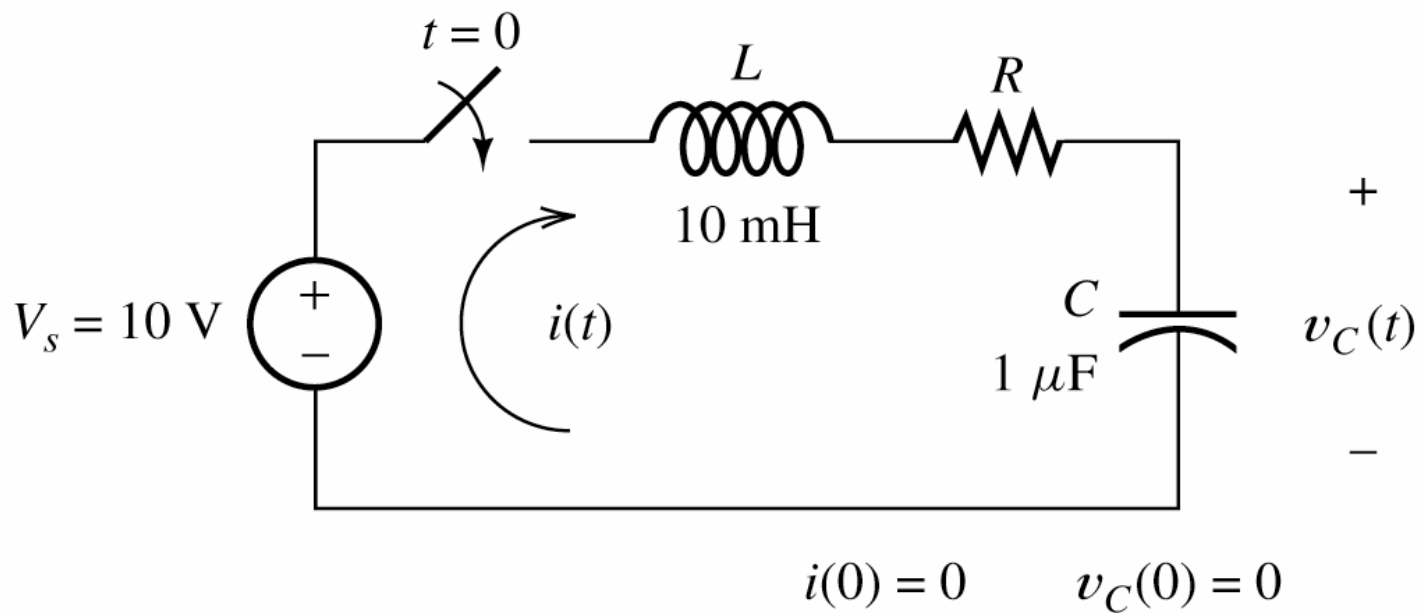

Figure 4.21 The circuit for Example 4.5.

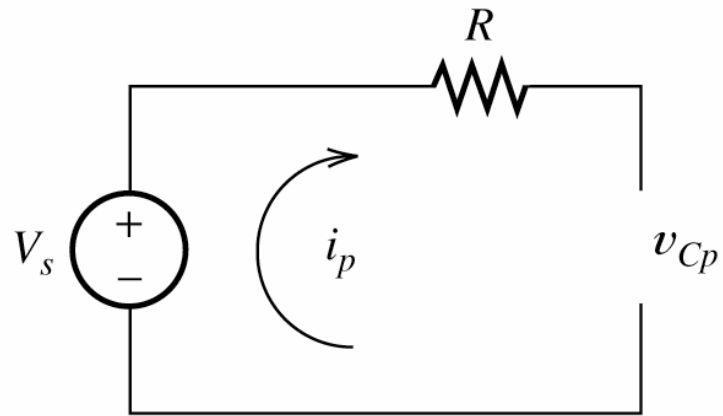

Figure 4.22 The equivalent circuit for Figure 4.21 under steady-state conditions. The inductor has been replaced by a short circuit and the capacitor by an open circuit.

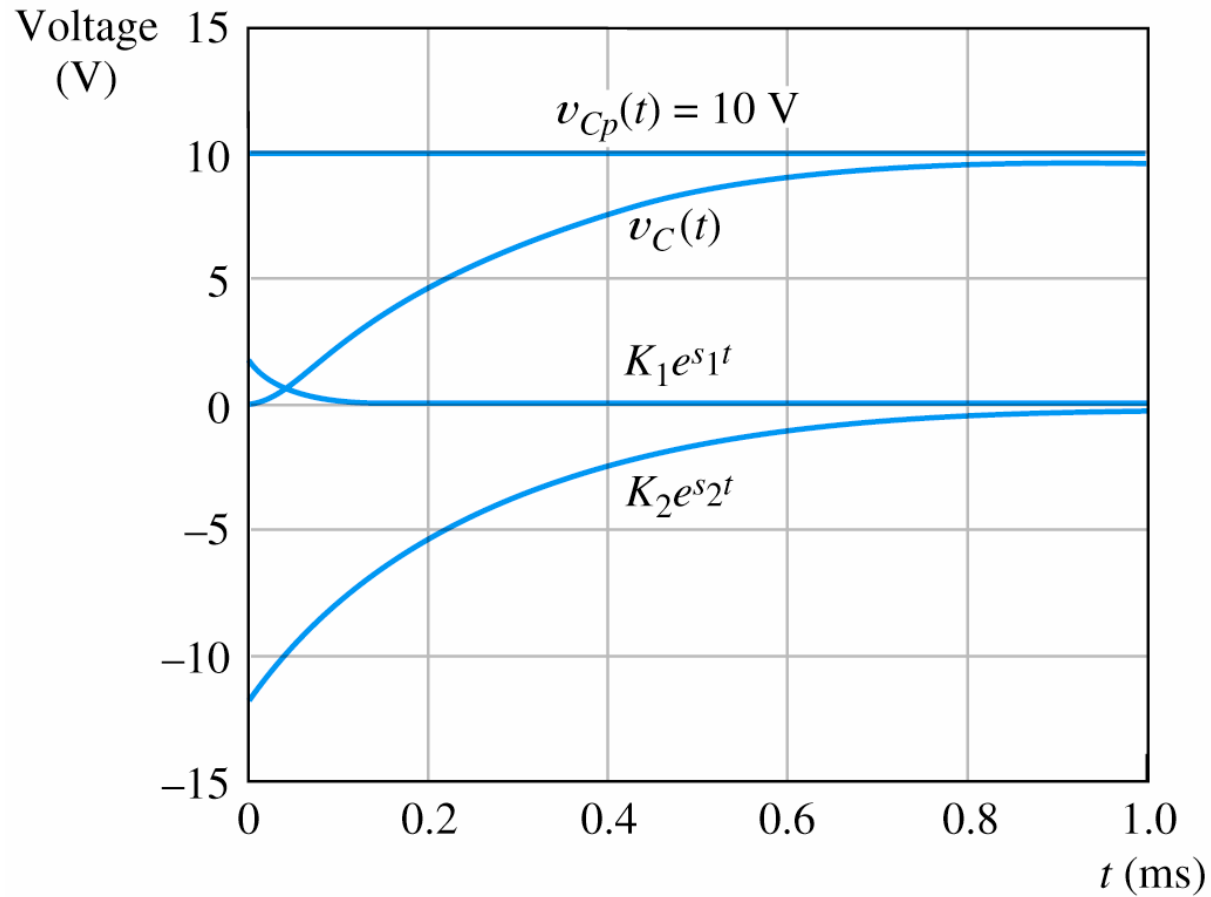

Figure 4.23 Solution for $R = 300 \Omega$.

(See text book for solution, particularly on the i.c.)

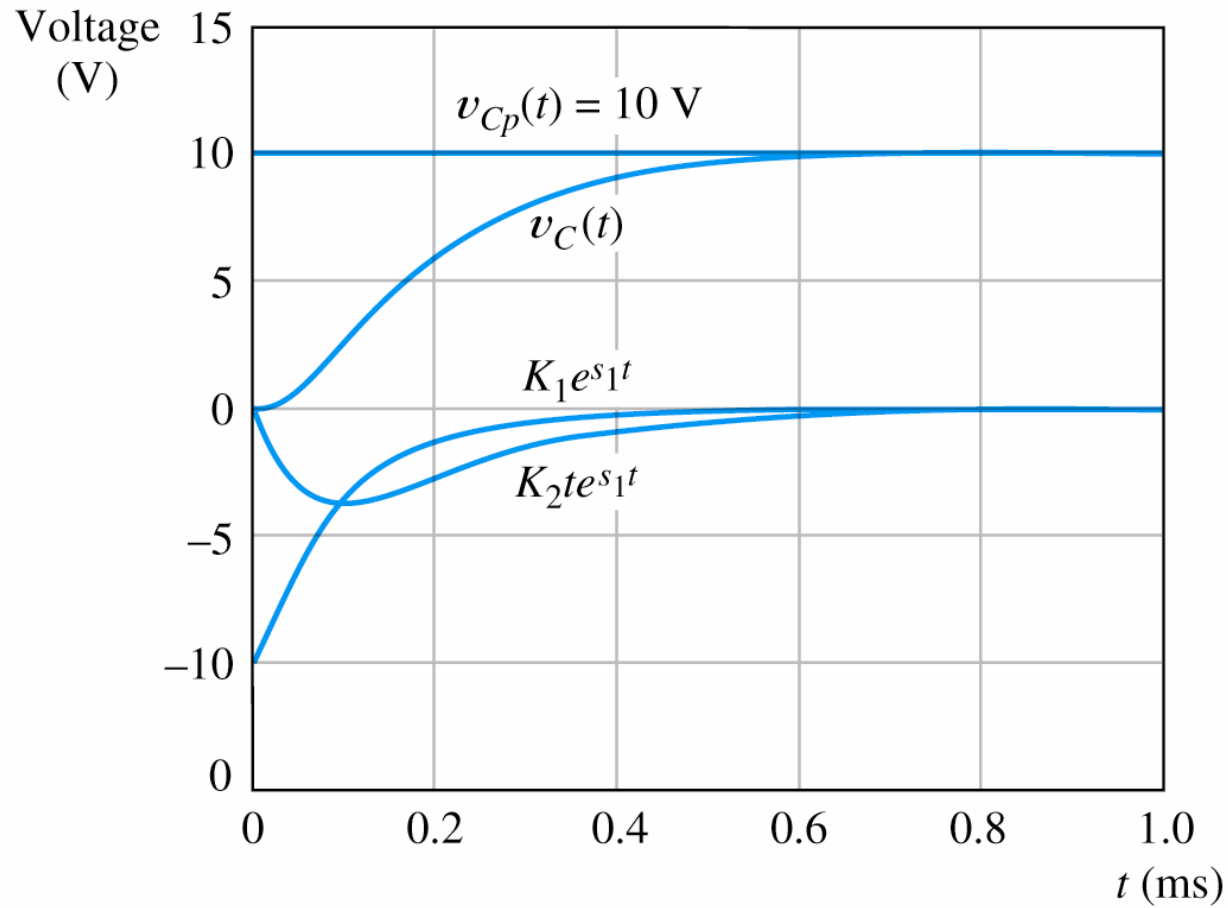

Figure 4.24 Solution for $R = 200 \Omega$.

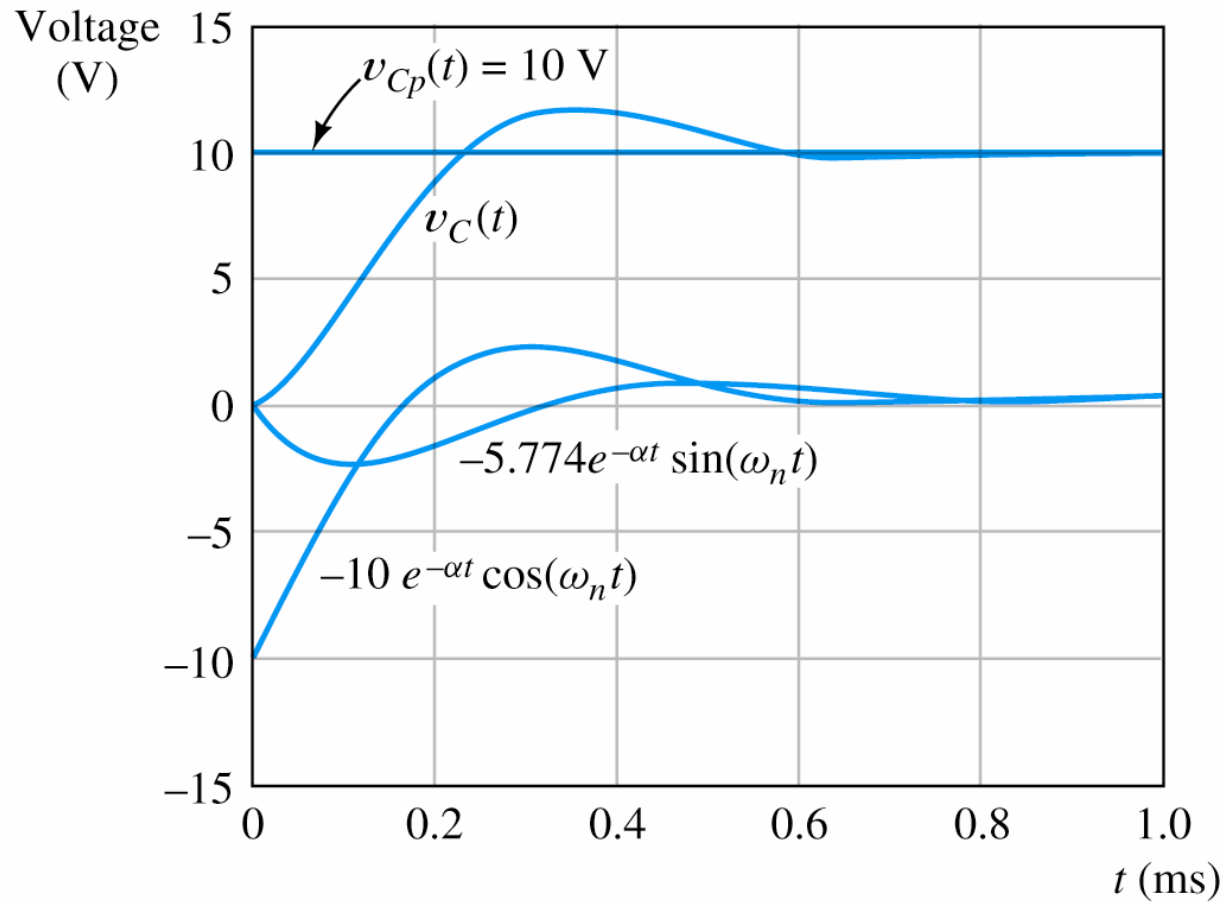

Figure 4.25 Solution for $R = 100 \Omega$.

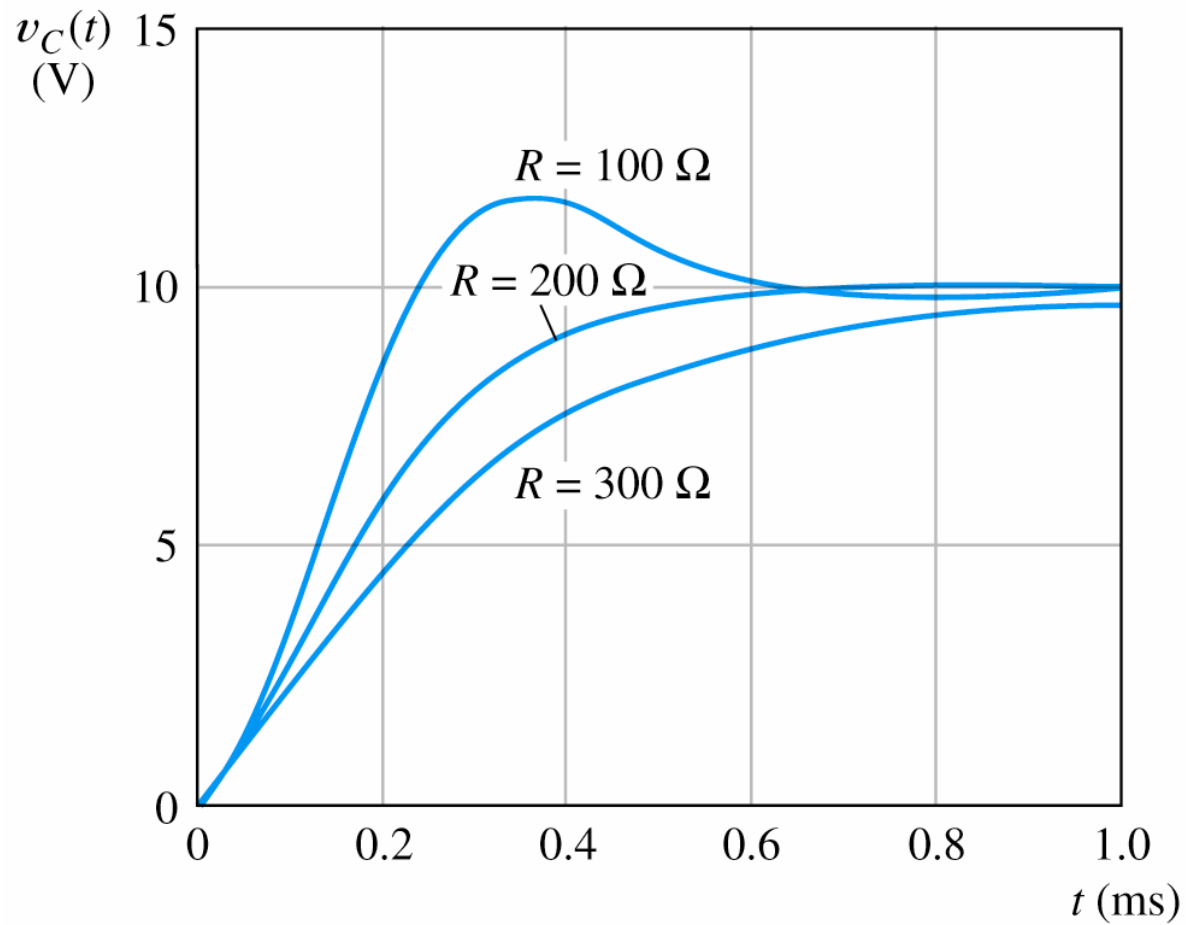

Figure 4.26 Solutions for all three resistances.

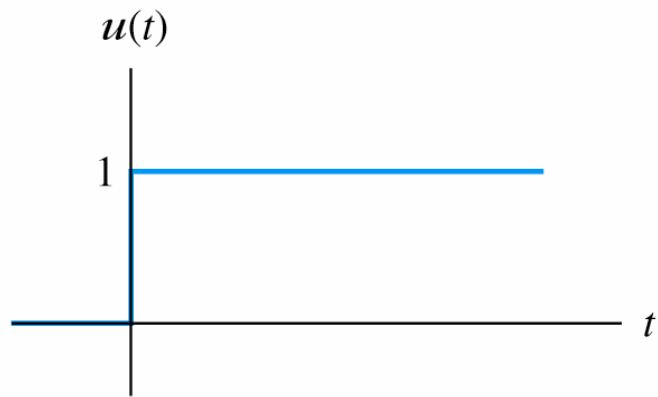

Figure 4.27 A unit step function $u(t)$. For $t < 0$, $u(t) = 0$. For $t \geq 0$, $u(t) = 1$.

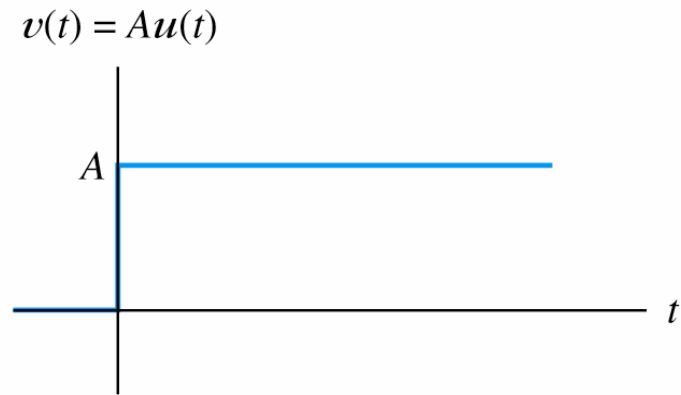
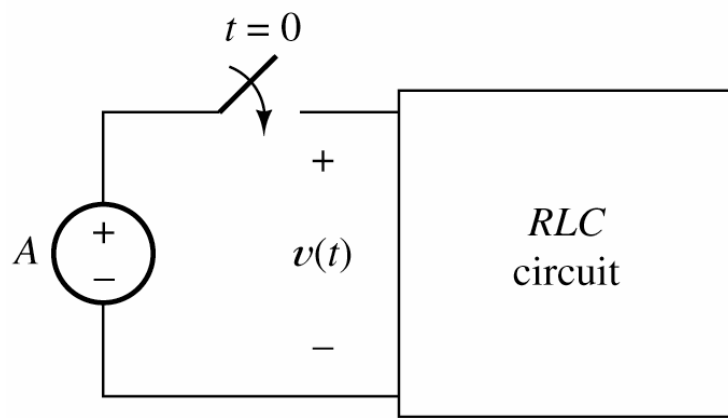

Figure 4.28 Applying a dc voltage by closing a switch results in a forcing function that is a step function.

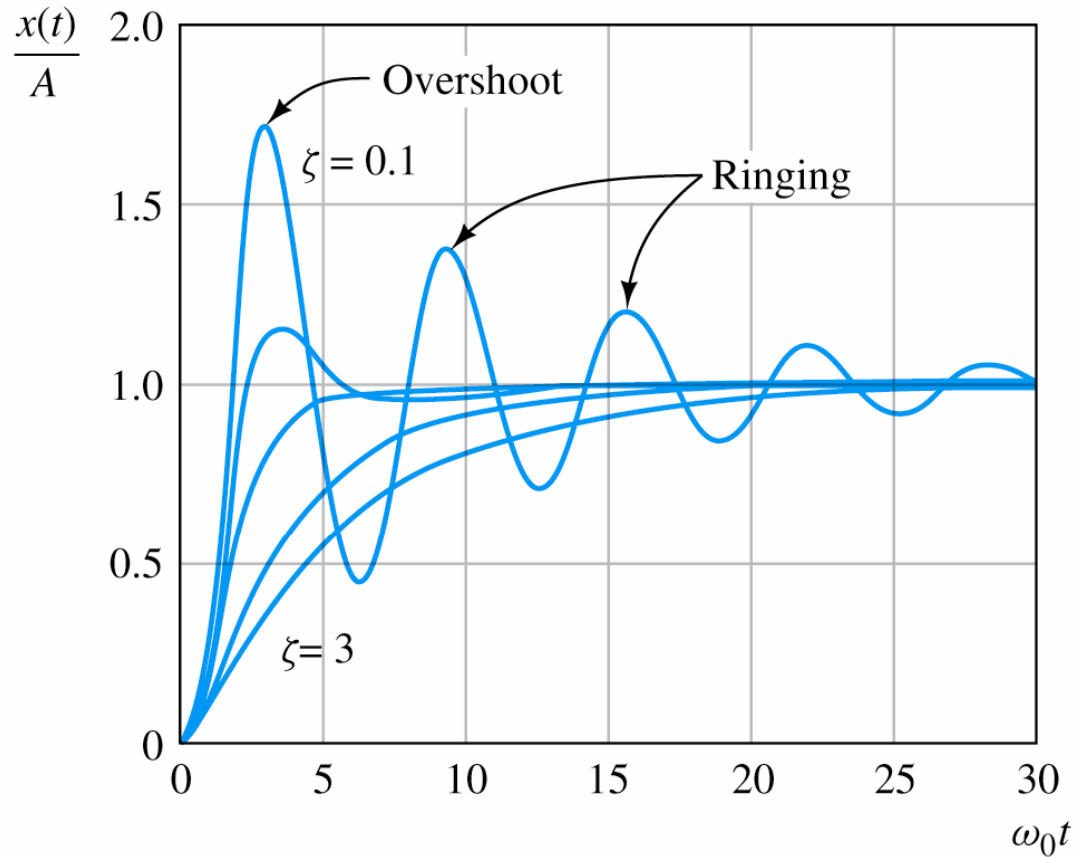

Figure 4.29 Normalized step responses for second-order systems described by Equation 4.99 with damping ratios of $\zeta = 0.1, 0.5, 1, 2,$ and 3 . The initial conditions are assumed to be $x(0) = 0$ and $x'(0) = 0$.

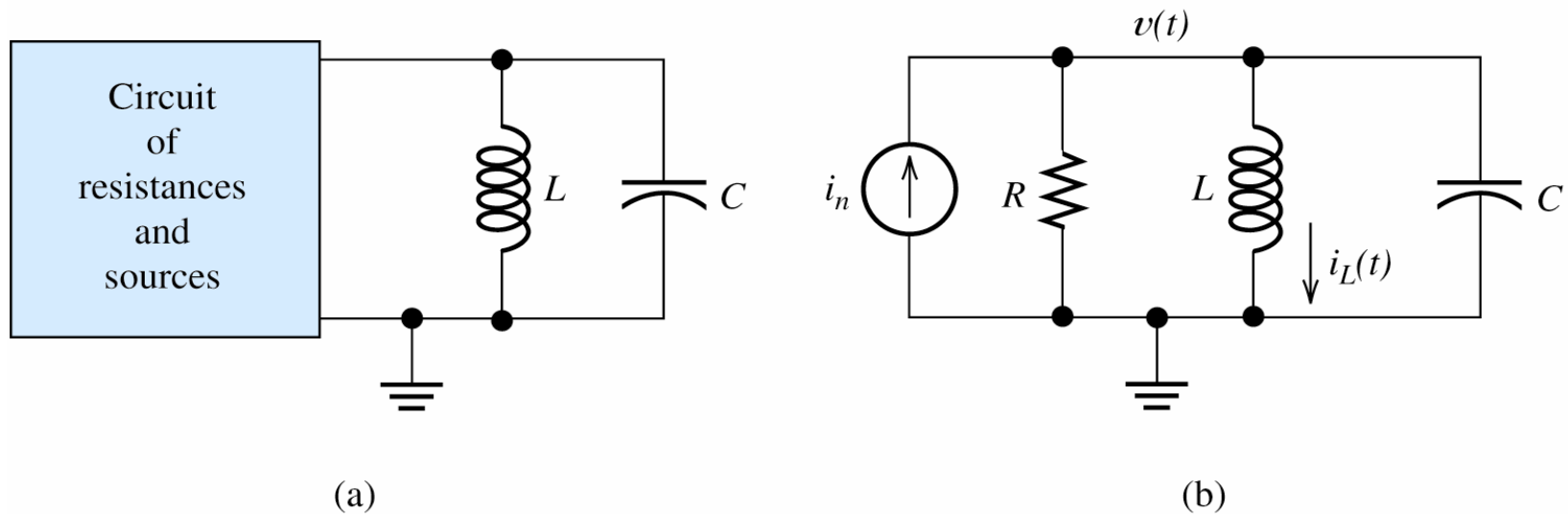

Figure 4.30 Any circuit consisting of sources, resistances, and a parallel LC combination can be reduced to the equivalent circuit shown in (b).

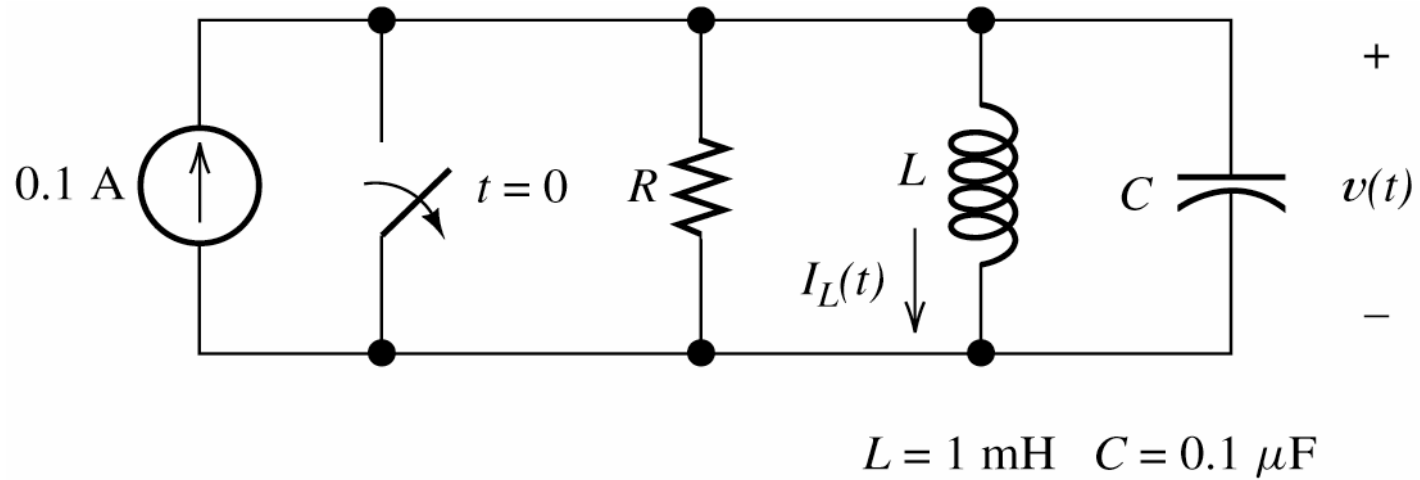

Figure 4.31 Circuit for Exercises 4.9, 4.10, and 4.11.

(Dual of the series circuit)

Problem Set

- 4, 7, 15, 21, 30, 35, 37, 45, 48