

Chapter 2: Resistive Circuits

Resistive Circuits

1. Solve circuits (i.e., find currents and voltages of interest) by combining resistances in series and parallel.
2. Apply the voltage-division and current-division principles.
3. Solve circuits by the node-voltage technique.



4. Solve circuits by the mesh-current technique.

5. Find Thévenin and Norton equivalents and apply source transformations.

6. Apply the superposition principle.

7. Draw the circuit diagram and state the principles of operation for the Wheatstone bridge.

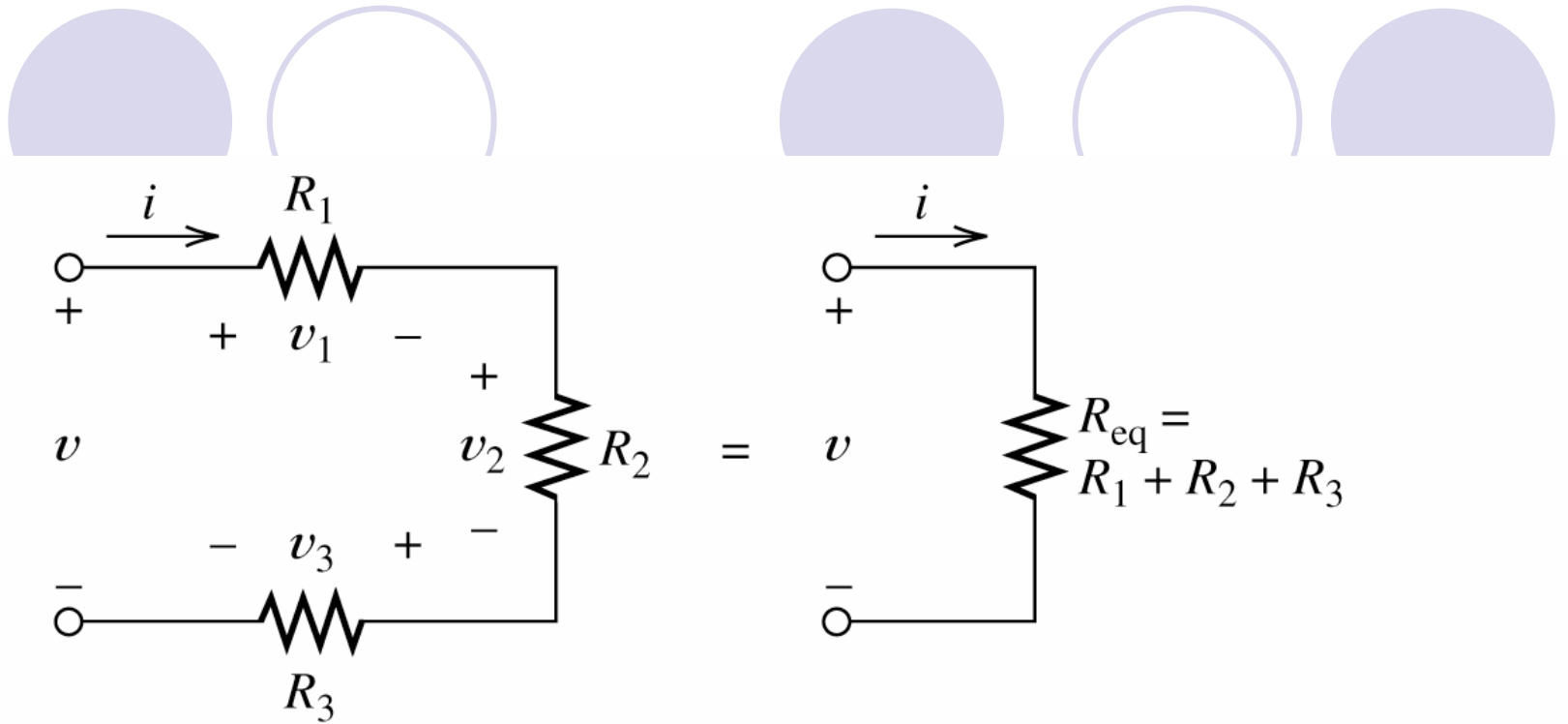

(a) Three resistances in series

(b) Equivalent resistance

Figure 2.1 Series resistances can be combined into an equivalent resistance.

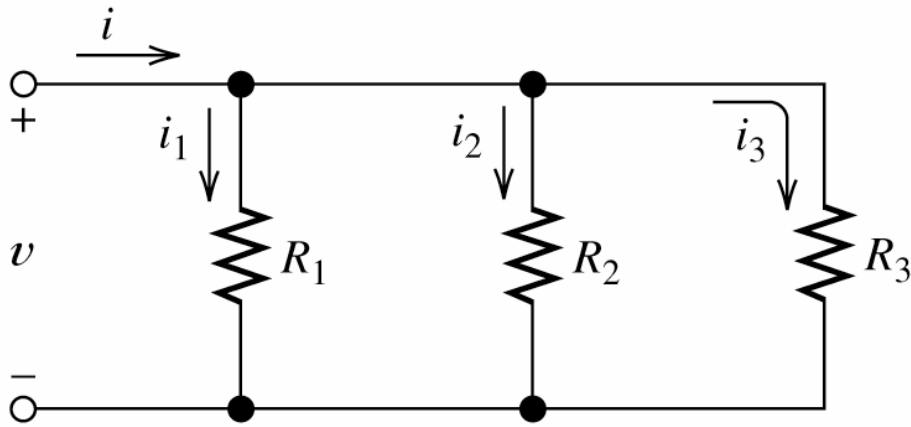
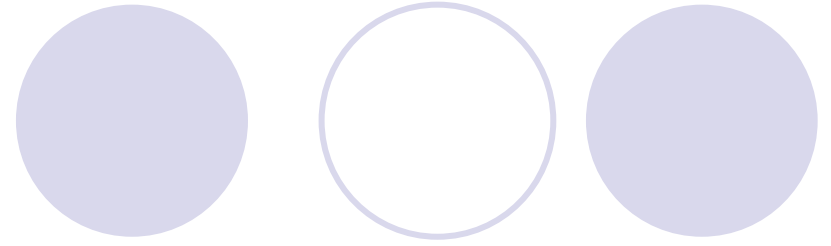
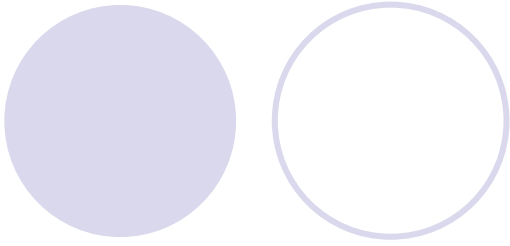

(a) Three resistances in parallel

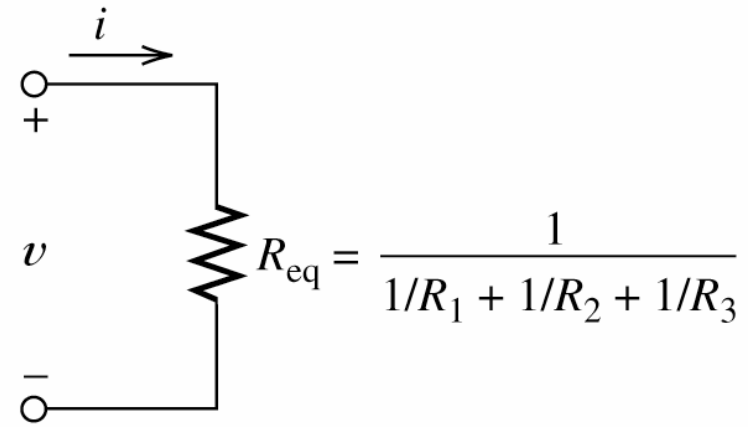

(b) Equivalent resistance

Figure 2.2 Parallel resistances can be combined into an equivalent resistance.

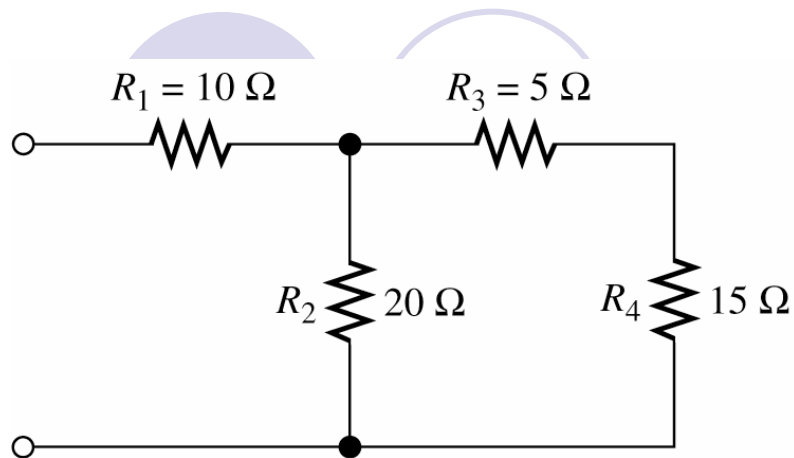

(a) Original network

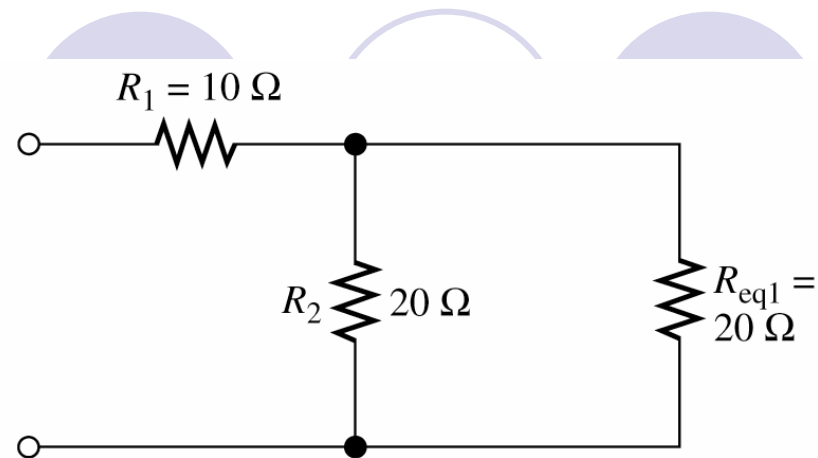

(b) Network after replacing R_3 and R_4 by their equivalent resistance

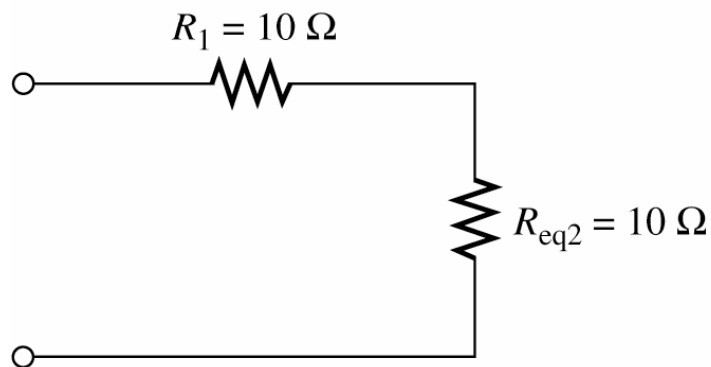

(c) Network after replacing R_2 and R_{eq1} by their equivalent

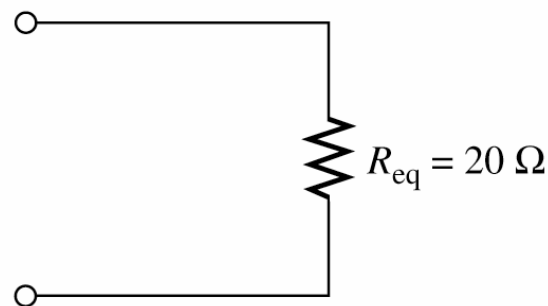

(d) Combining R_1 and R_{eq2} in series yields the equivalent resistance of the entire network

Figure 2.3 Resistive network for Example 2.1.

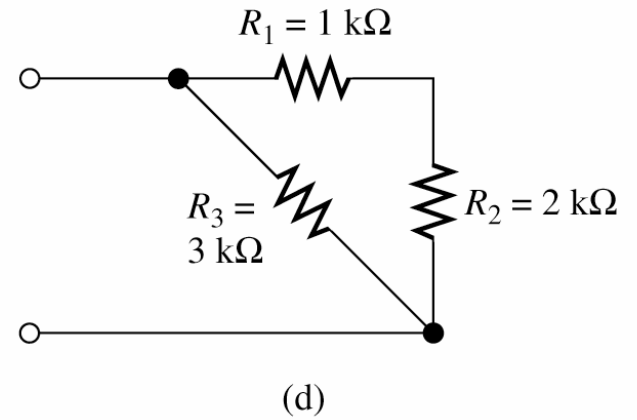
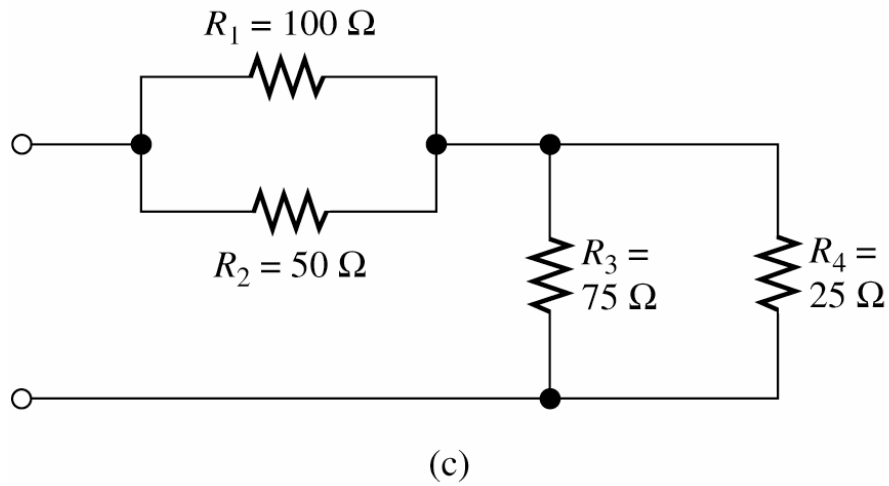
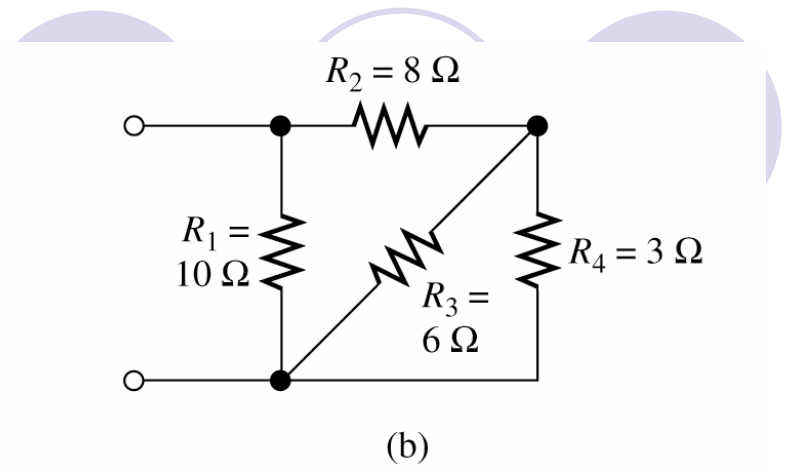
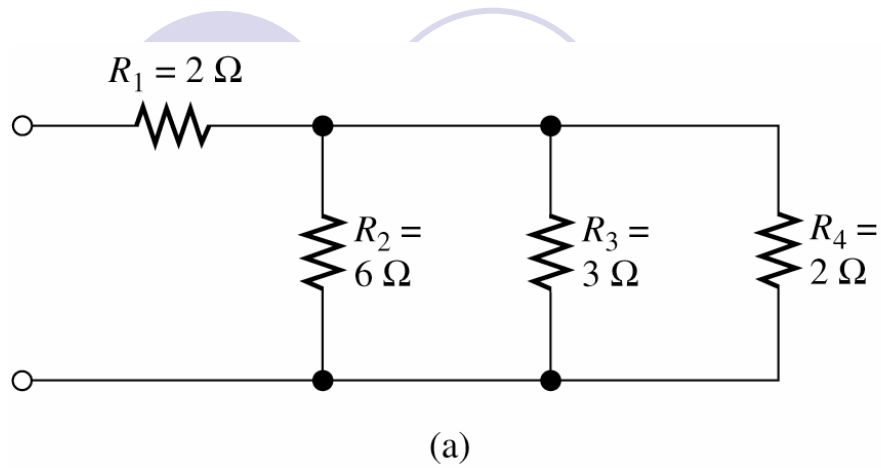
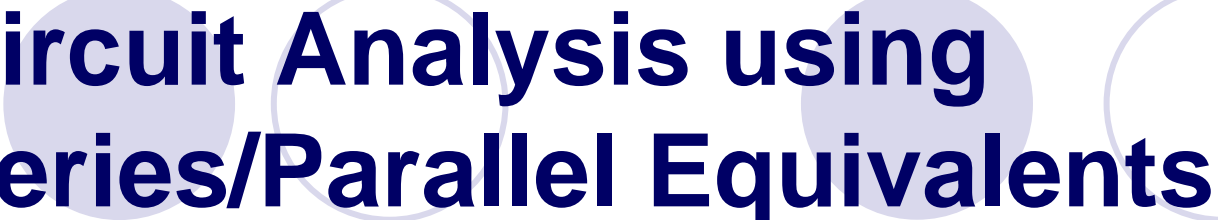



Figure 2.4 Resistive networks for Exercise 2.1.

Circuit Analysis using Series/Parallel Equivalents

The title is centered at the top of the slide. To its right are four decorative circles of varying shades of light blue and white, arranged in a horizontal line.

1. Begin by locating a combination of resistances that are in series or parallel. Often the place to start is farthest from the source.
2. Redraw the circuit with the equivalent resistance for the combination found in step 1.

- 
- The slide features five decorative circles at the top, arranged in a horizontal line. They alternate in style: a solid light purple circle, an outlined light purple circle, a solid light purple circle, an outlined light purple circle, and a solid light purple circle.
3. Repeat steps 1 and 2 until the circuit is reduced as far as possible. Often (but not always) we end up with a single source and a single resistance.
 4. Solve for the currents and voltages in the final equivalent circuit.

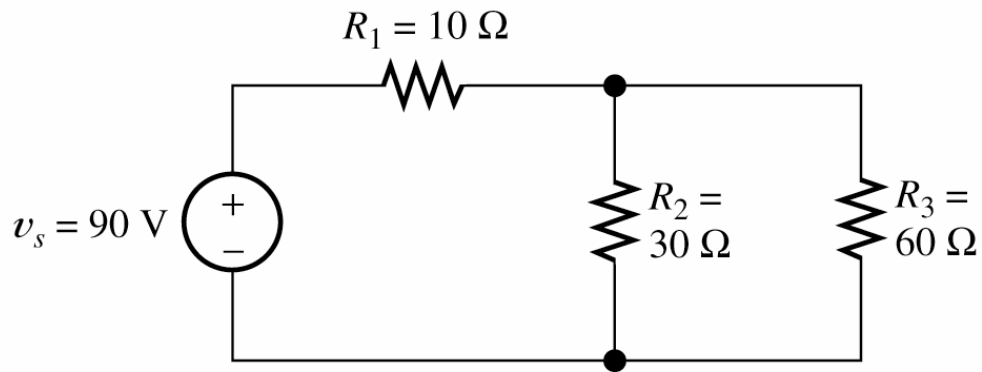

(a) Original circuit

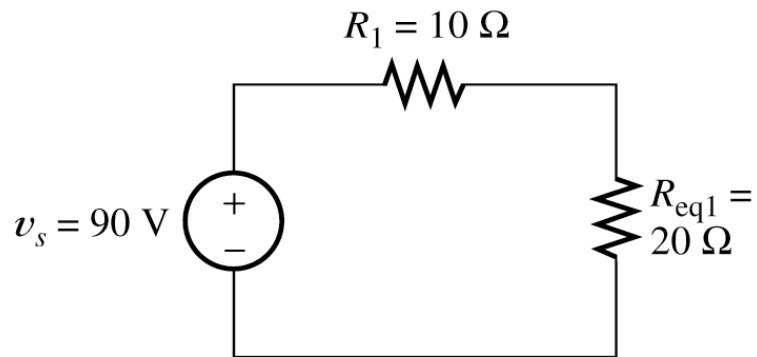

(b) Circuit after replacing R_2 and R_3 by their equivalent

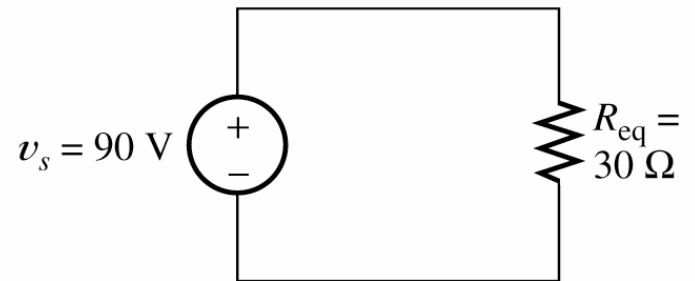

(c) Circuit after replacing R_1 and $R_{\text{eq}1}$ by their equivalent

Figure 2.5 A circuit and its simplified versions. See Example 2.2.

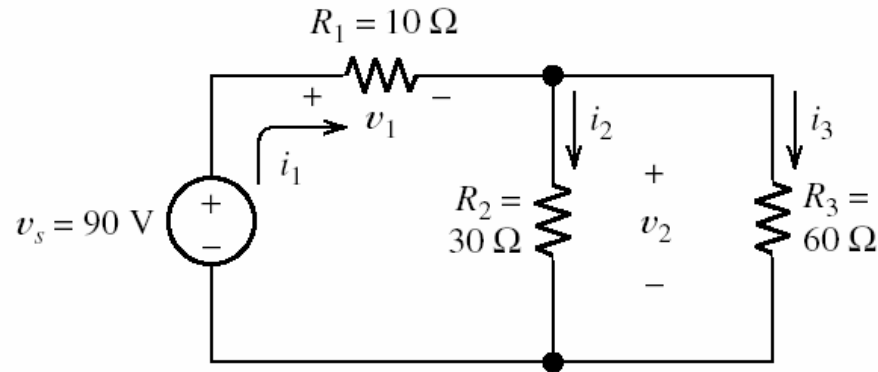

(a) Third, we use known values of i_1 and v_2 to solve for the remaining currents and voltages

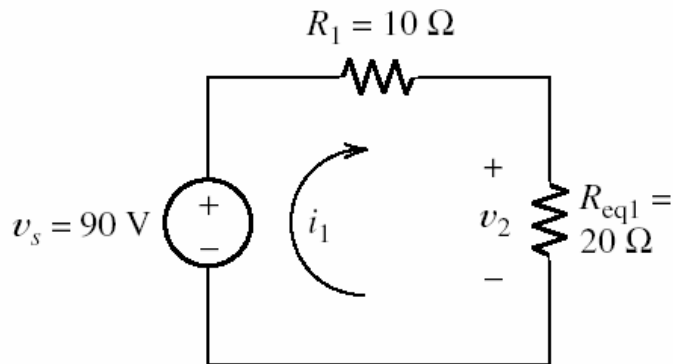

(b) Second, we find $v_2 = R_{eq1} i_1 = 60 \text{ V}$

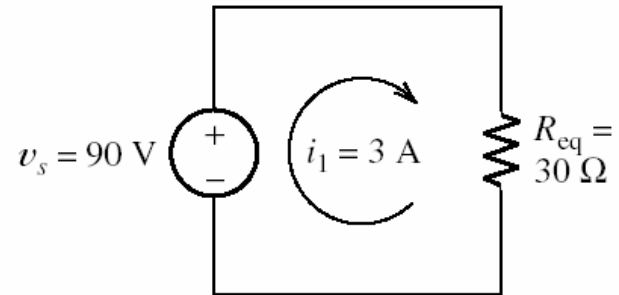

(c) First, we solve for $i_1 = \frac{v_s}{R_{eq}} = 3 \text{ A}$

Figure 2.6 After reducing the circuit to a source and an equivalent resistance, we solve the simplified circuit. Then, we transfer results back to the original circuit. Notice that the logical flow in solving for currents and voltages starts from the simplified circuit in (c).

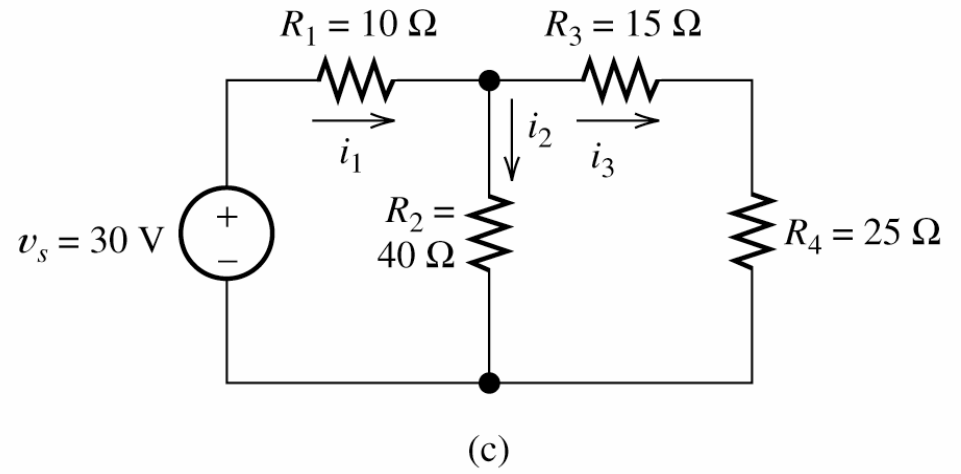
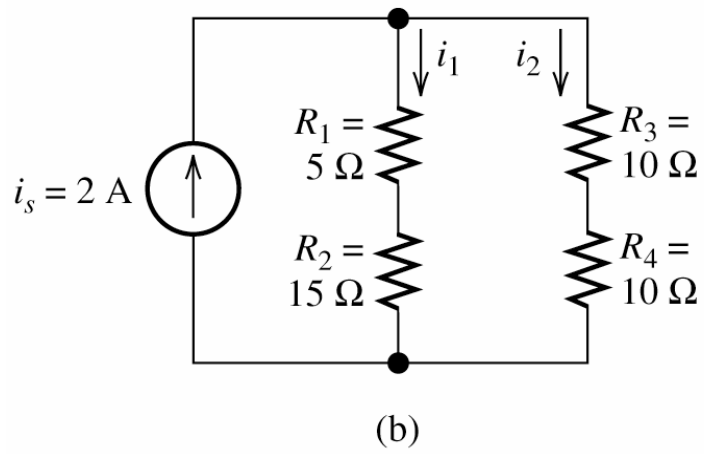
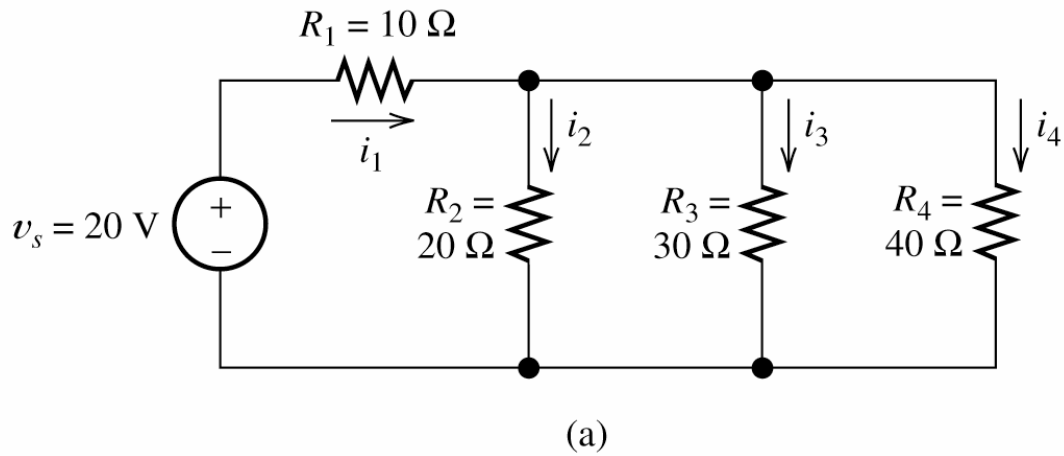

Figure 2.7 Circuits for Exercise 2.2.

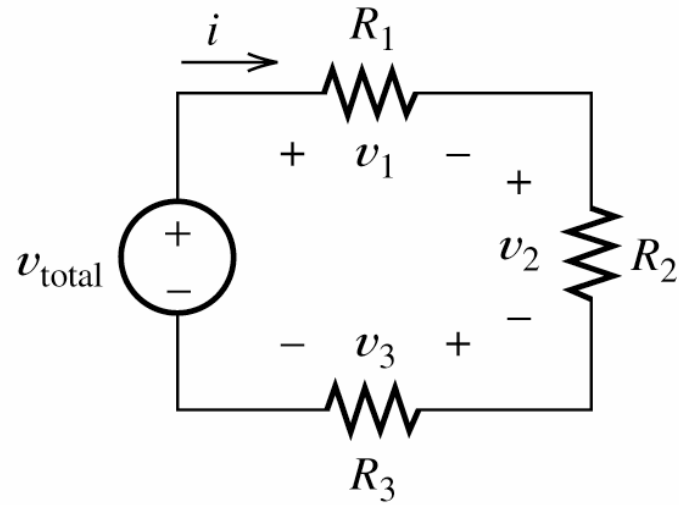
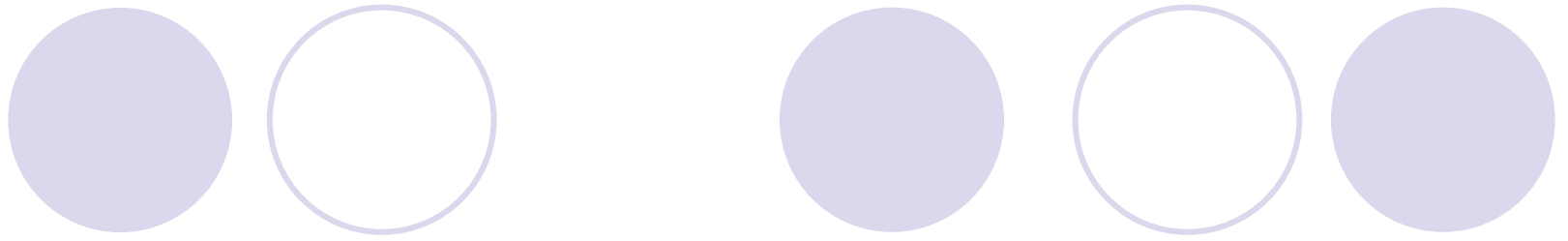
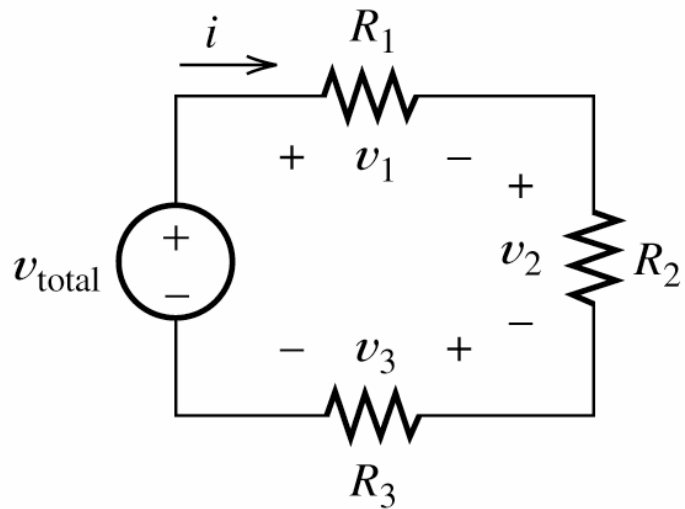

Figure 2.8 Circuit used to derive the voltage-division principle.

Voltage Division



$$v_1 = R_1 i = \frac{R_1}{R_1 + R_2 + R_3} v_{\text{total}}$$

$$v_2 = R_2 i = \frac{R_2}{R_1 + R_2 + R_3} v_{\text{total}}$$

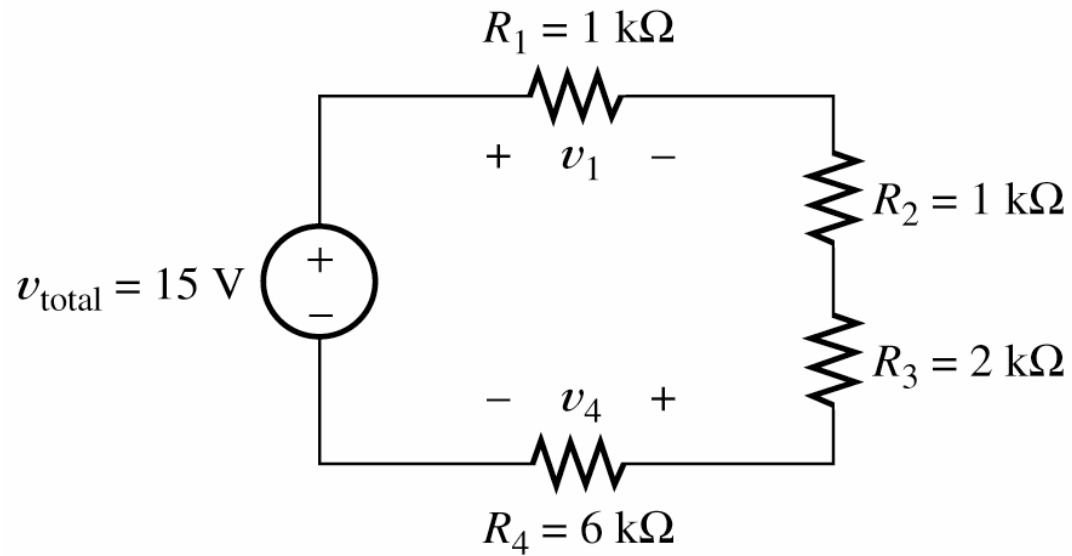
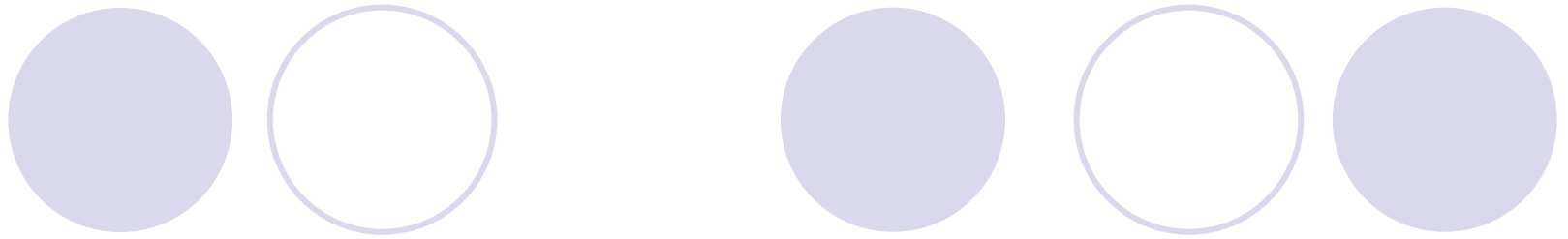
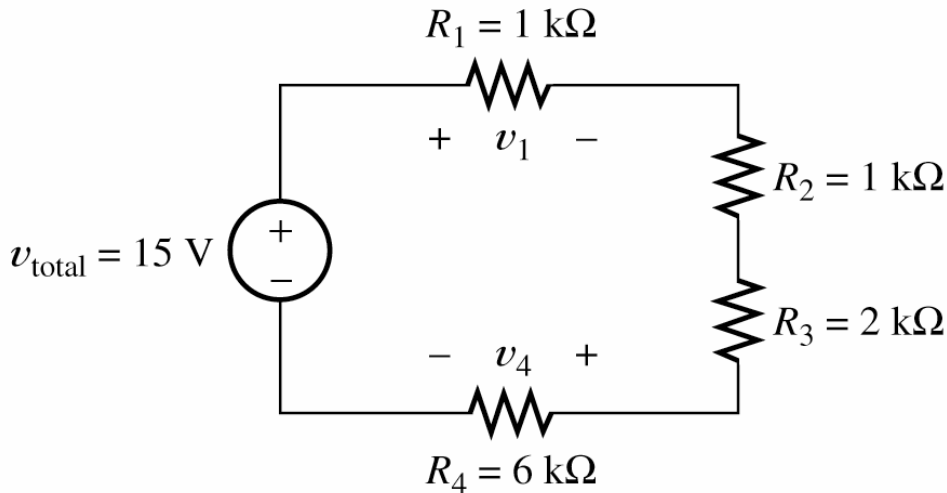

Figure 2.9 Circuit for Example 2.3.

Application of the Voltage-Division Principle



$$\begin{aligned} v_1 &= \frac{R_1}{R_1 + R_2 + R_3 + R_4} v_{\text{total}} \\ &= \frac{1000}{1000 + 1000 + 2000 + 6000} \times 15 \\ &= 1.5 \text{ V} \end{aligned}$$

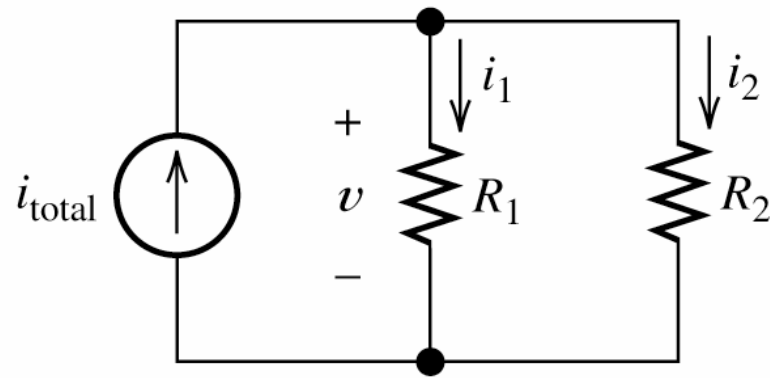
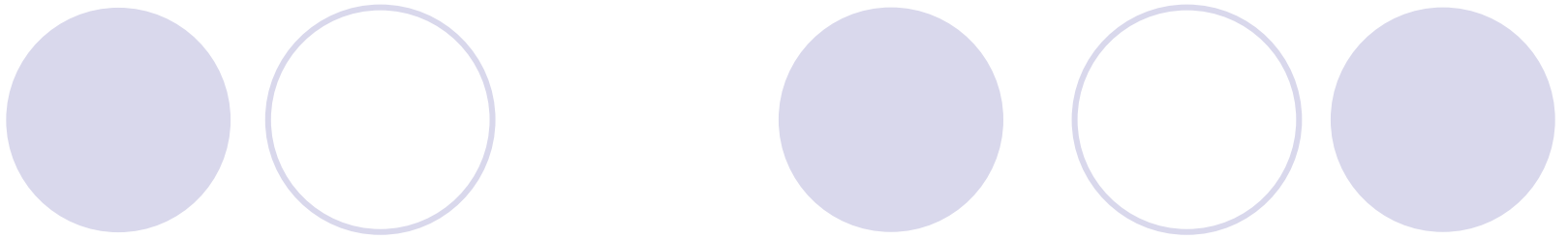
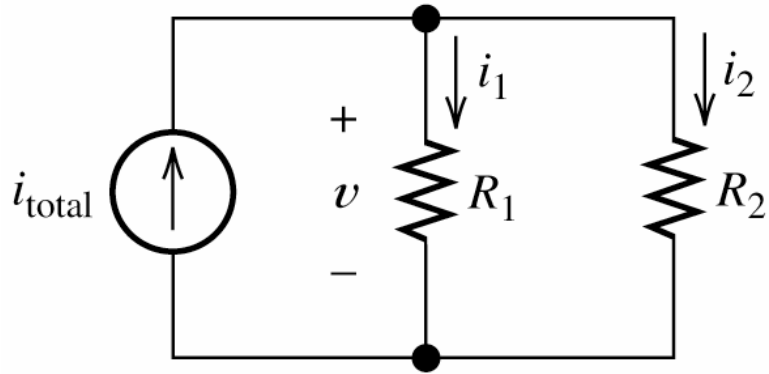
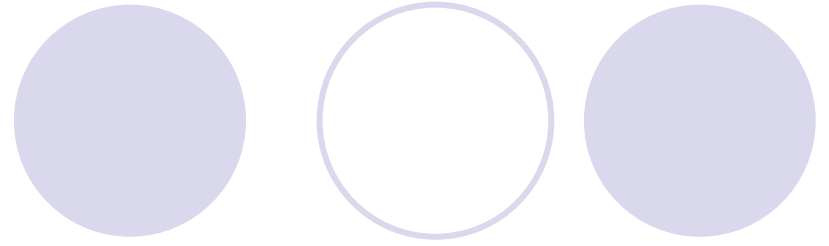
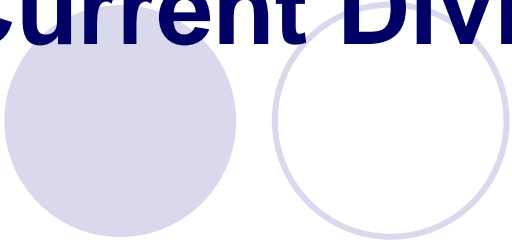

Figure 2.10 Circuit used to derive the current-division principle.

Current Division



$$i_1 = \frac{v}{R_1} = \frac{R_2}{R_1 + R_2} i_{\text{total}}$$

$$i_2 = \frac{v}{R_2} = \frac{R_1}{R_1 + R_2} i_{\text{total}}$$

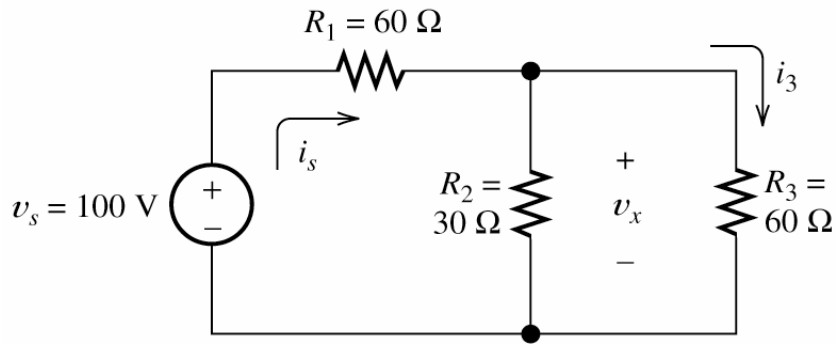
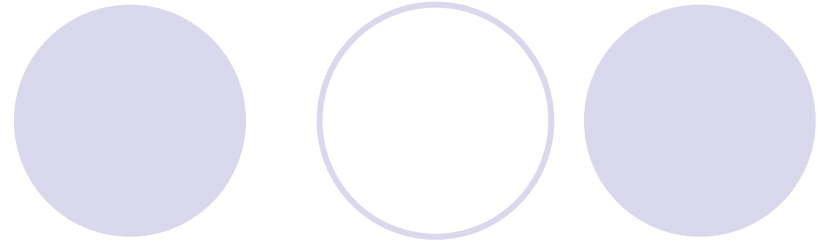
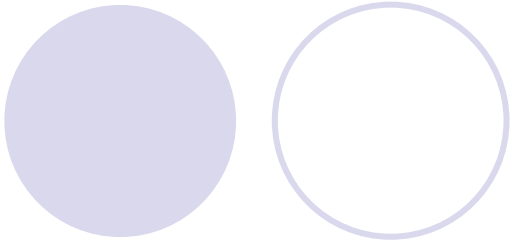

(a) Original circuit

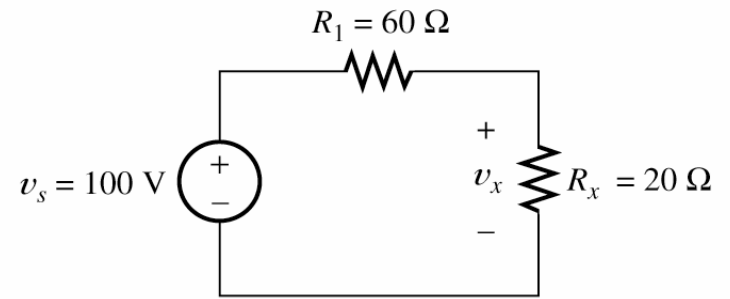

(b) Equivalent circuit obtained by combining R_2 and R_3

Figure 2.11 Circuit for Example 2.4.

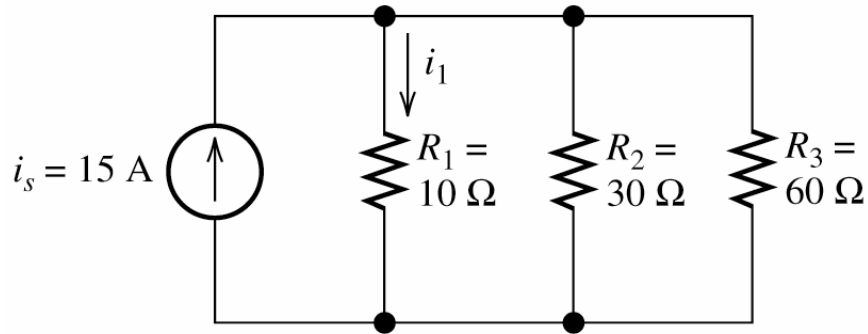
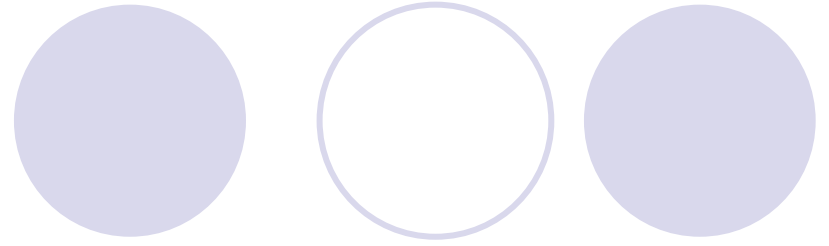
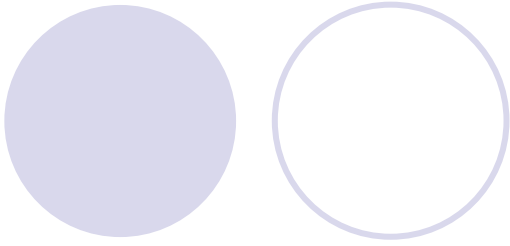

(a) Original circuit

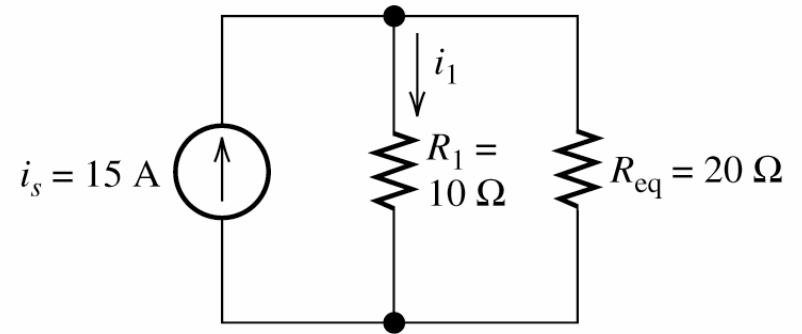

(b) Circuit after combining R_2 and R_3

Figure 2.12 Circuit for Example 2.5.

Application of the Current-Division Principle

$$R_{\text{eq}} = \frac{R_2 R_3}{R_2 + R_3} = \frac{30 \times 60}{30 + 60} = 20\Omega$$

$$i_1 = \frac{R_{\text{eq}}}{R_1 + R_{\text{eq}}} i_s = \frac{20}{10 + 20} 15 = 10\text{A}$$

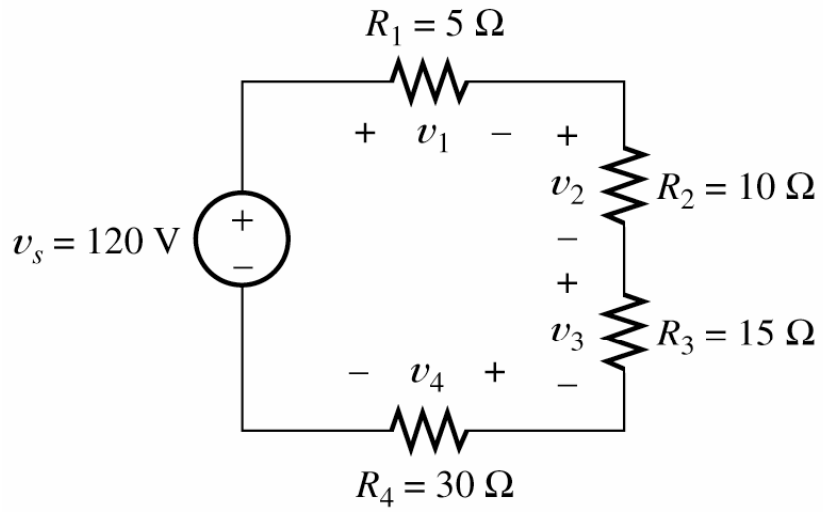
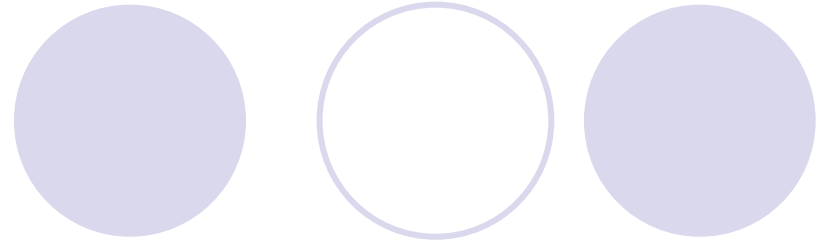
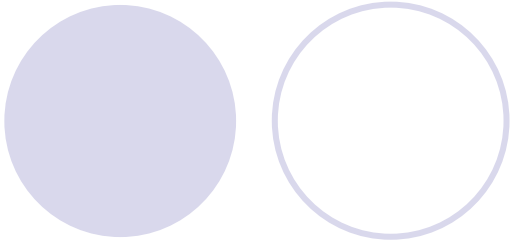

(a)

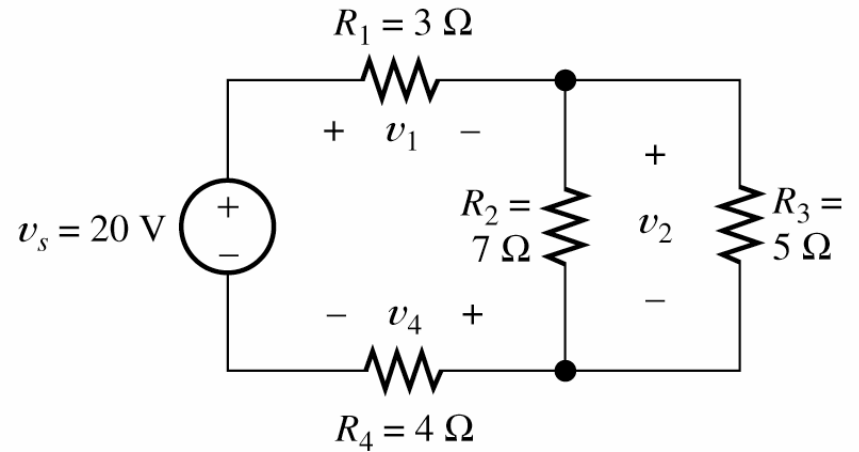

(b)

Figure 2.14 Circuits for Exercise 2.3.

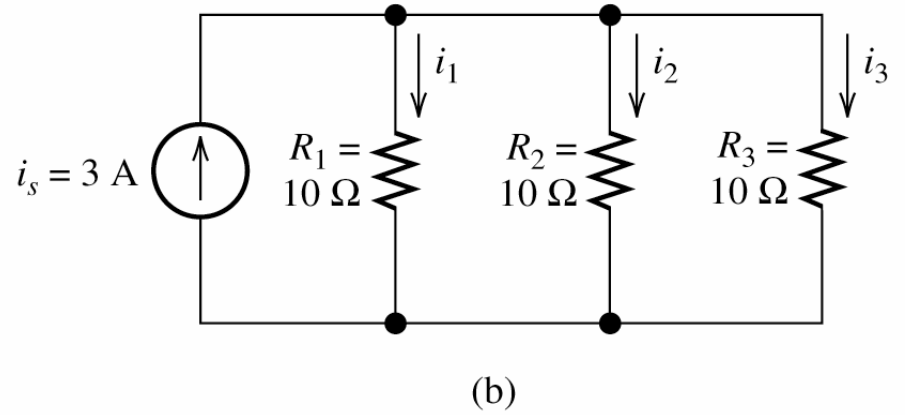
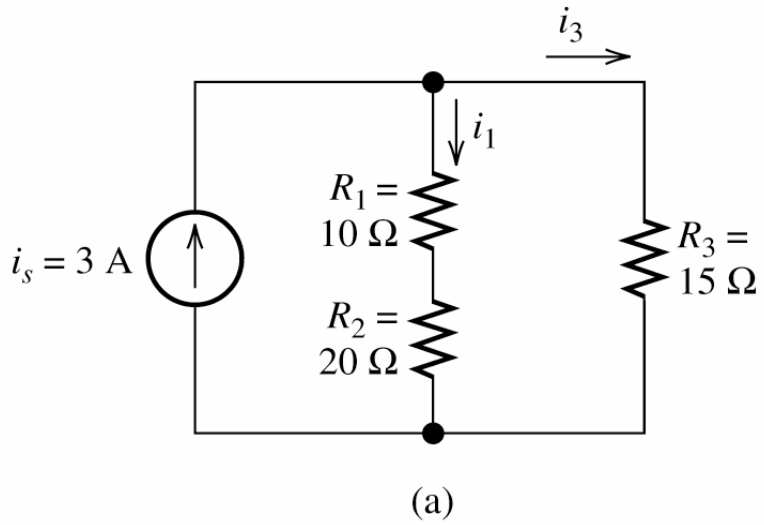
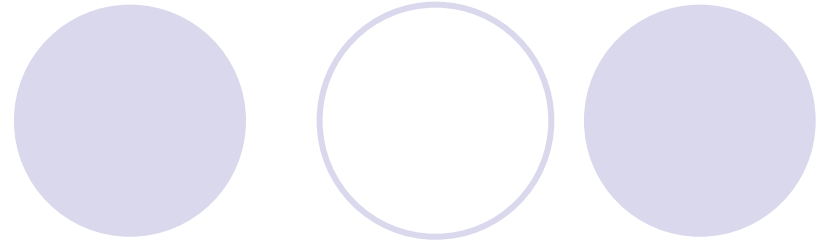
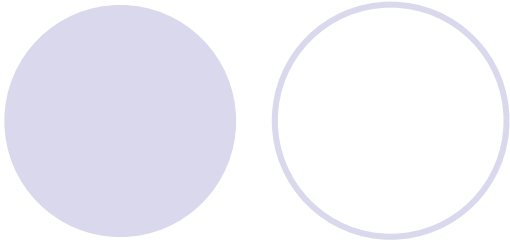

Figure 2.15 Circuits for Exercise 2.4.



Although they are very important concepts, series/parallel equivalents and the current/voltage division principles are not sufficient to solve all circuits.

Node Voltage Analysis

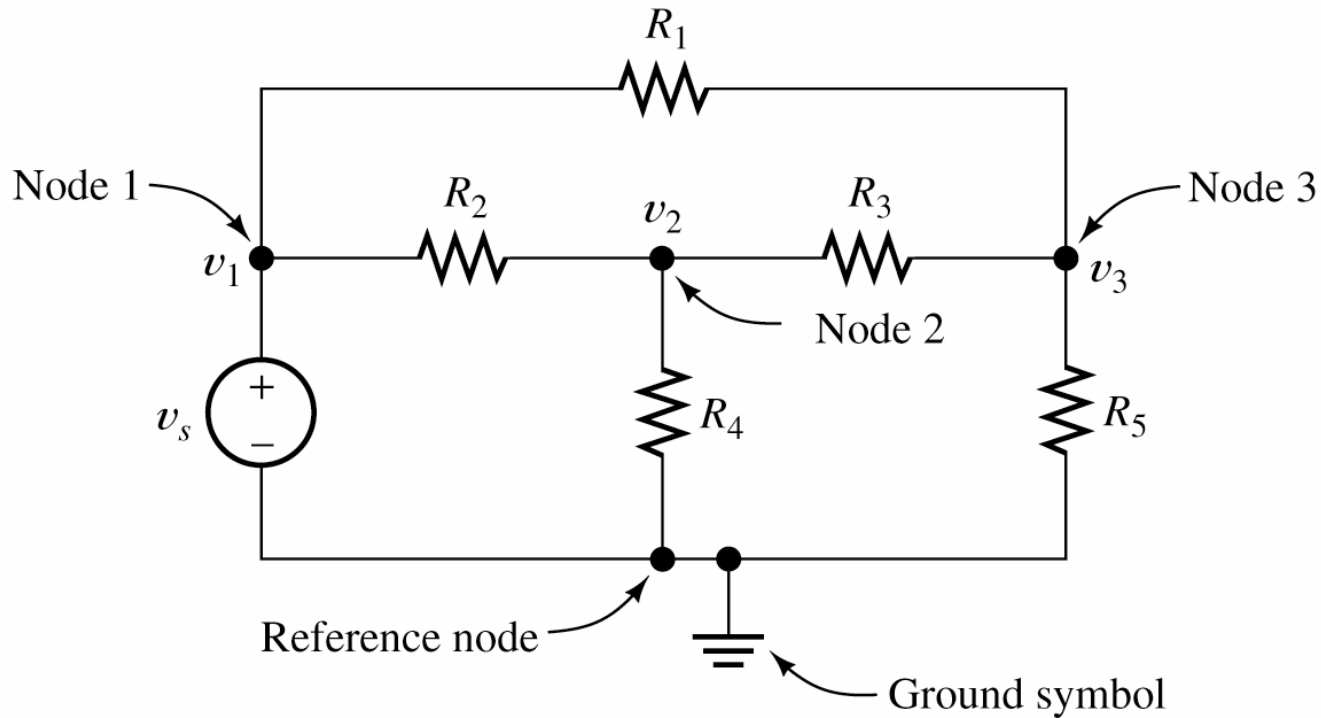

Figure 2.16 The first step in node analysis is to select a reference node and label the voltages at each of the other nodes.

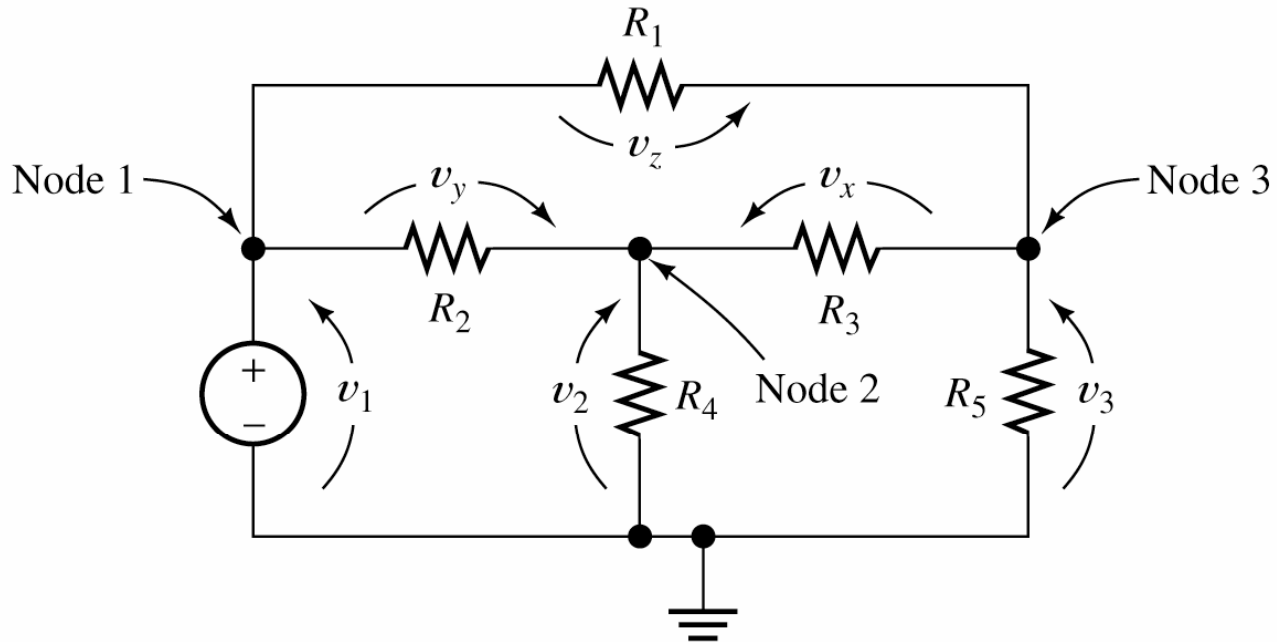
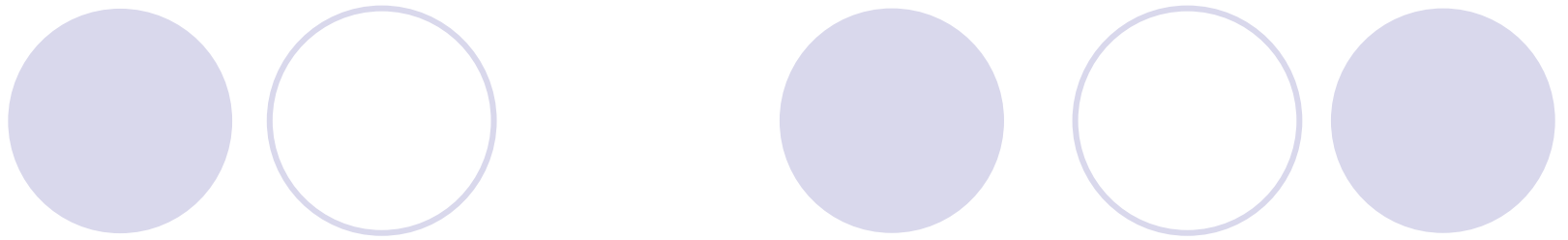

Figure 2.17 Assuming that we can determine the node voltages v_1 , v_2 , and v_3 , we can use KVL to determine v_x , v_y , and v_z . Then using Ohm's law, we can find the current in each of the resistances. Thus, the key problem is in determining the node voltages.

Writing KCL Equations in Terms of the Node Voltages for Figure 2.16

$$v_1 = v_s$$

$$\frac{v_2 - v_1}{R_2} + \frac{v_2}{R_4} + \frac{v_2 - v_3}{R_3} = 0$$

$$\frac{v_3 - v_1}{R_1} + \frac{v_3}{R_5} + \frac{v_3 - v_2}{R_3} = 0$$

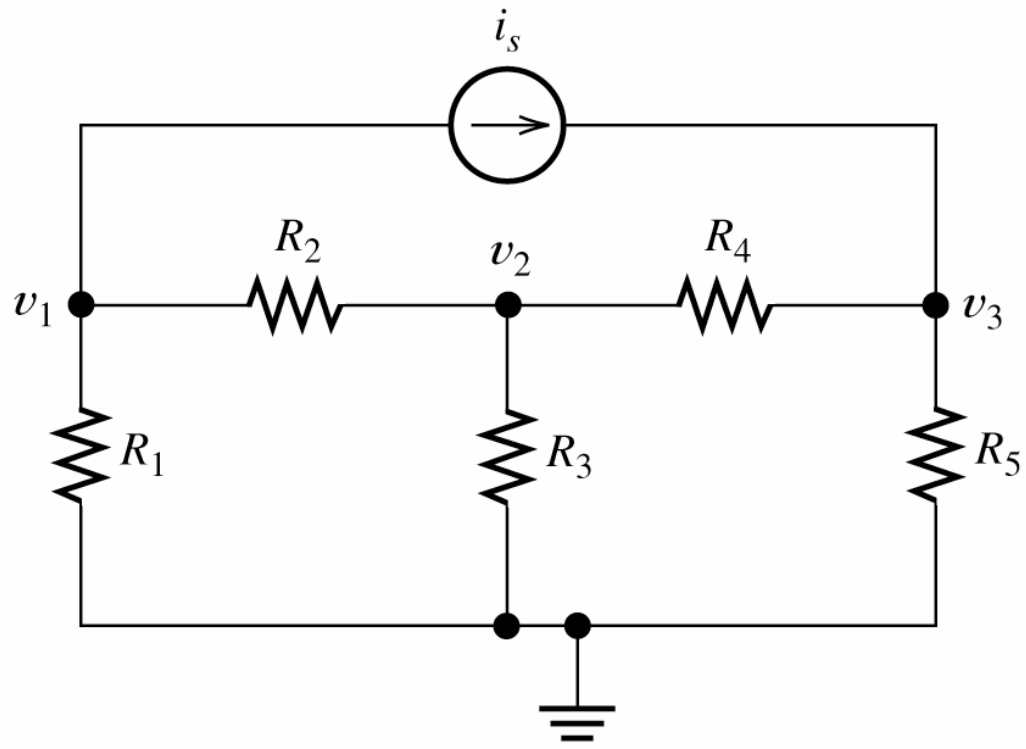
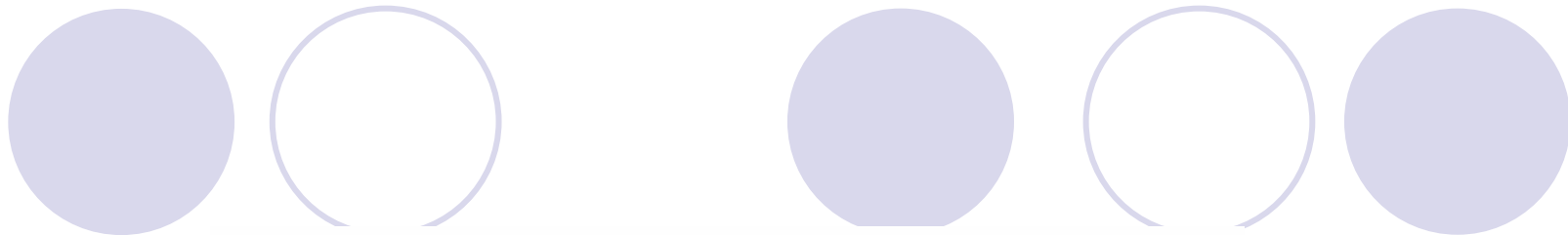
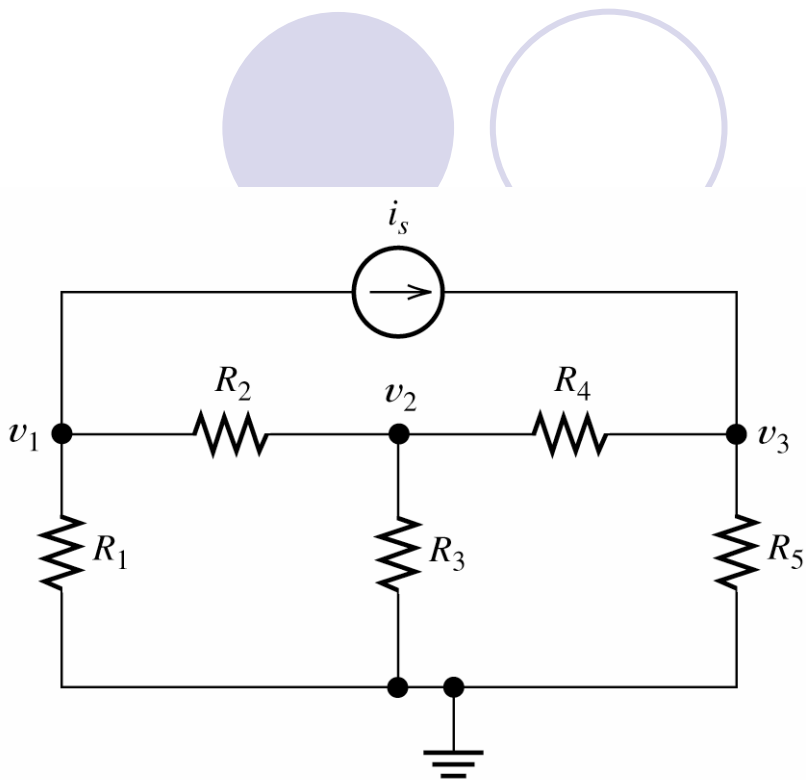

Figure 2.18 Circuit for Example 2.6.



$$\frac{v_1}{R_1} + \frac{v_1 - v_2}{R_2} + i_s = 0$$

$$\frac{v_2 - v_1}{R_2} + \frac{v_2}{R_3} + \frac{v_2 - v_3}{R_4} = 0$$

$$\frac{v_3}{R_5} + \frac{v_3 - v_2}{R_4} = i_s$$

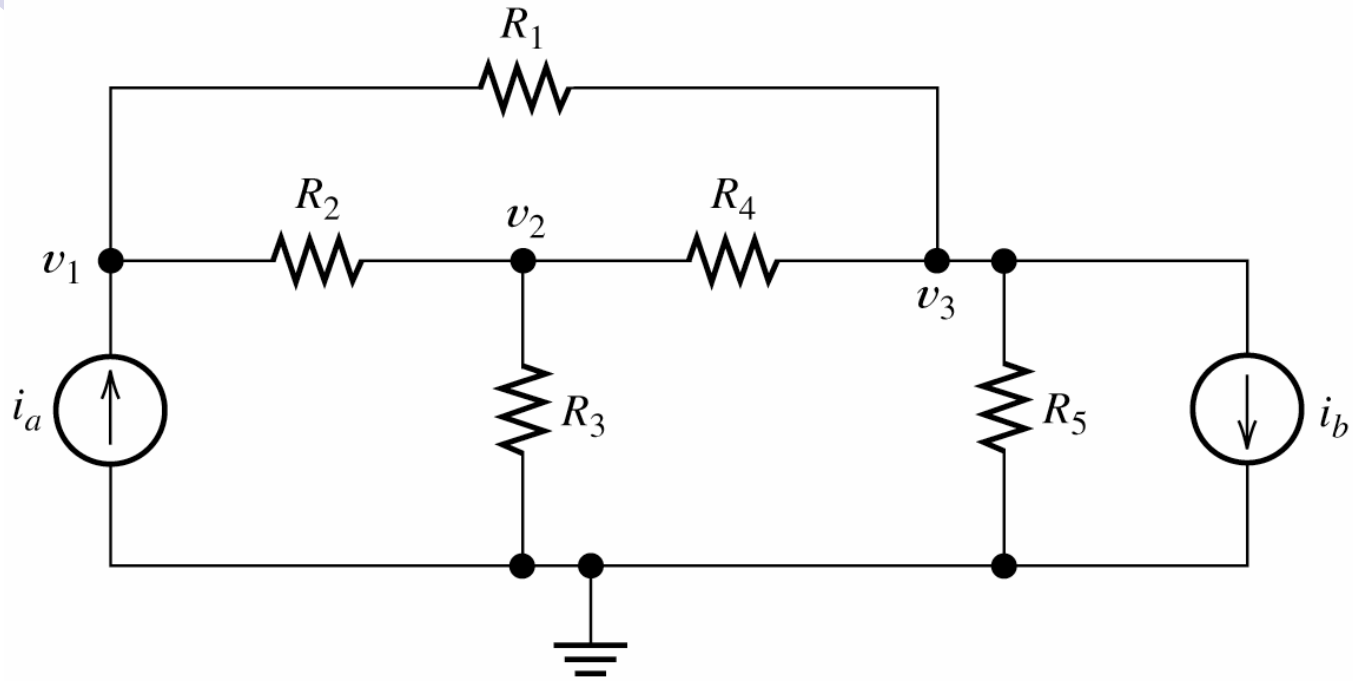

Figure 2.19 Circuit for Exercise 2.6.

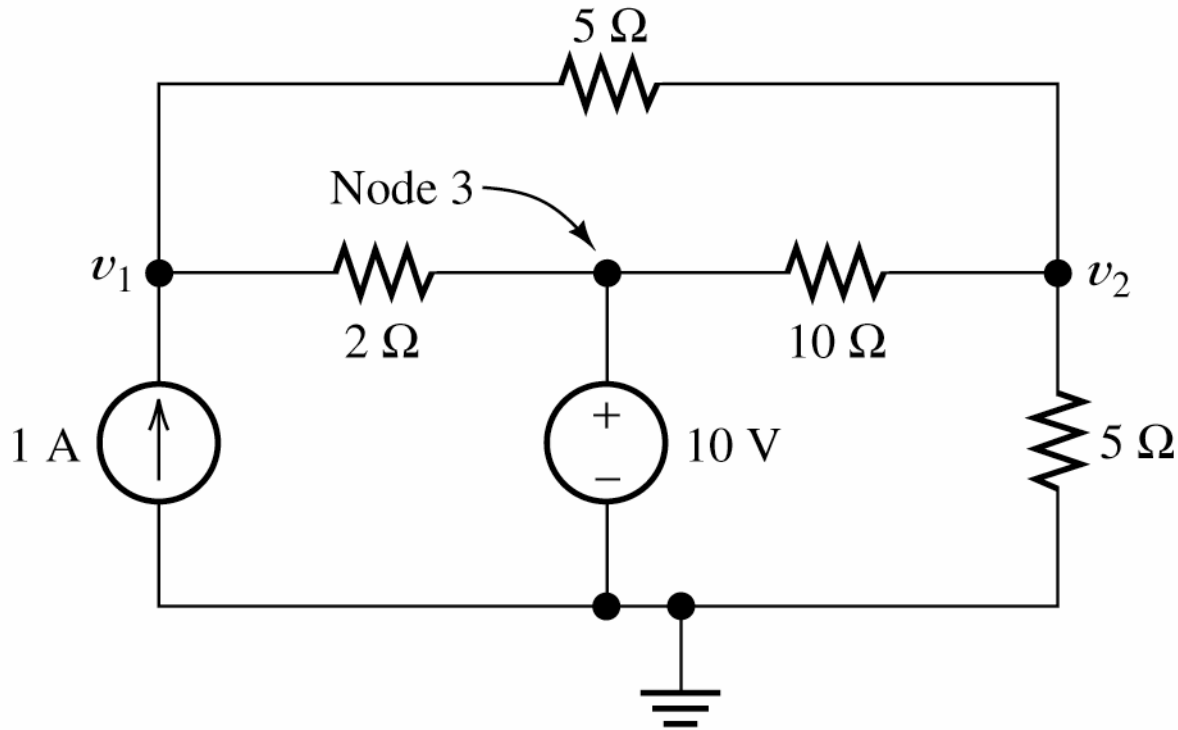

Figure 2.20 Circuit for Example 2.7.

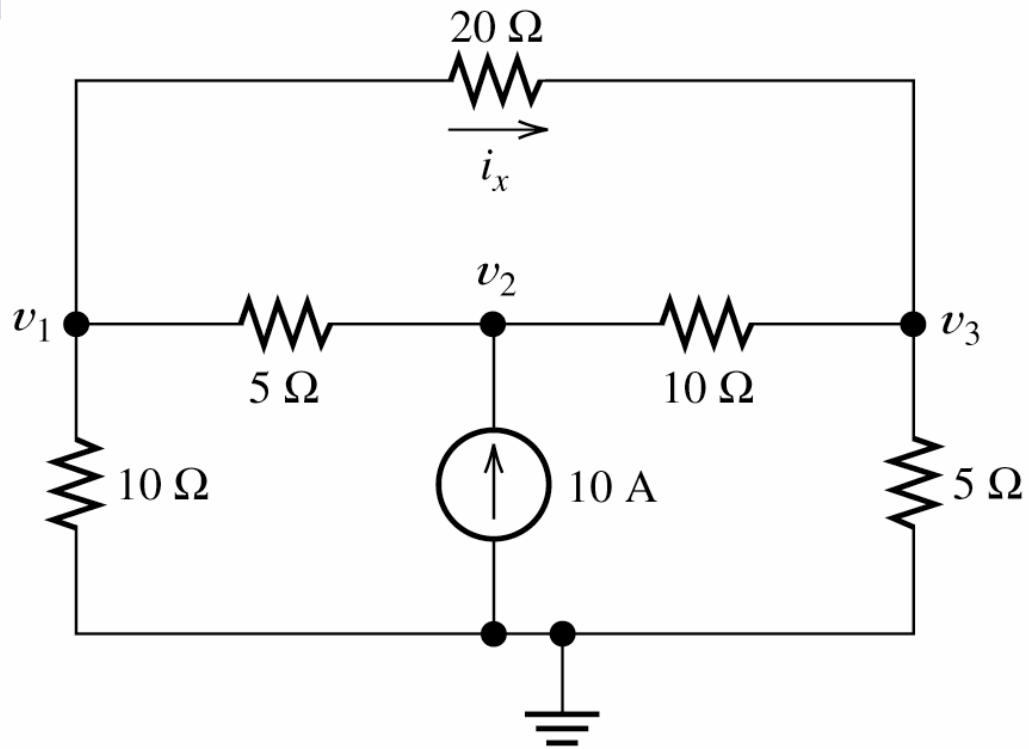

Figure 2.21 Circuit for Example 2.8.

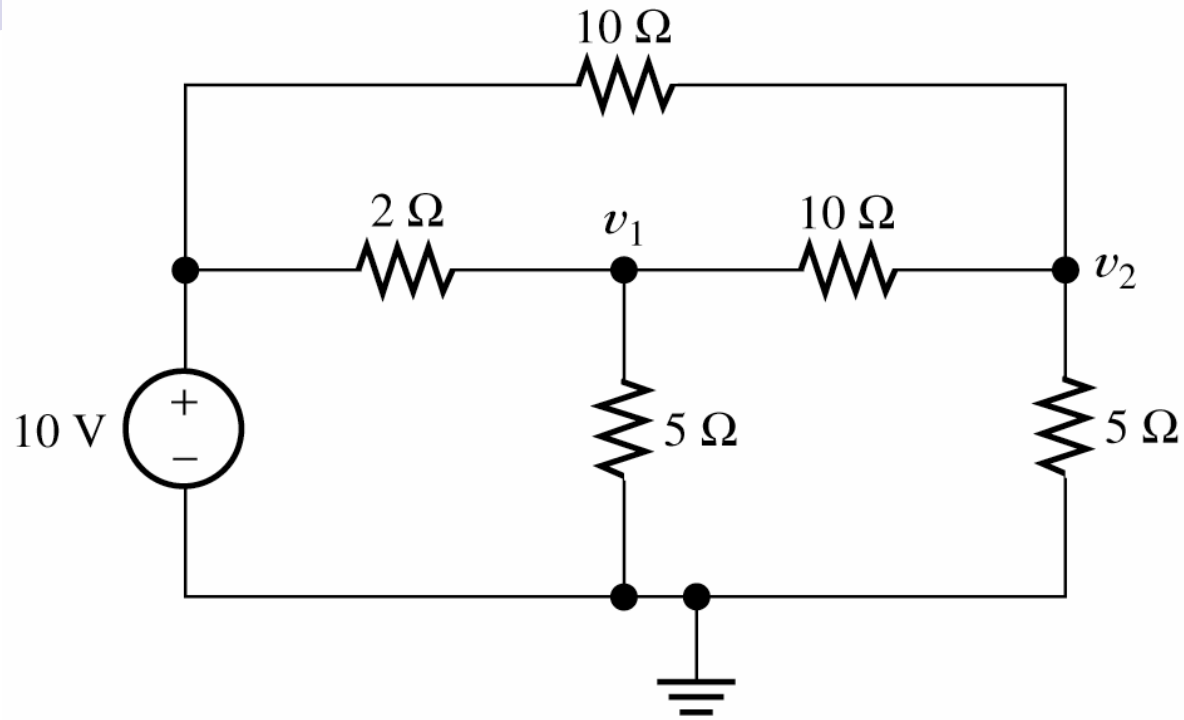
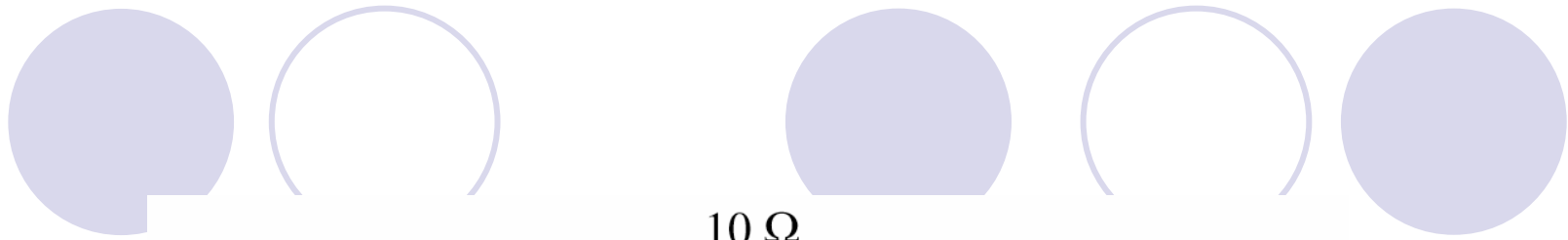

Figure 2.22 Circuit for Exercise 2.8.

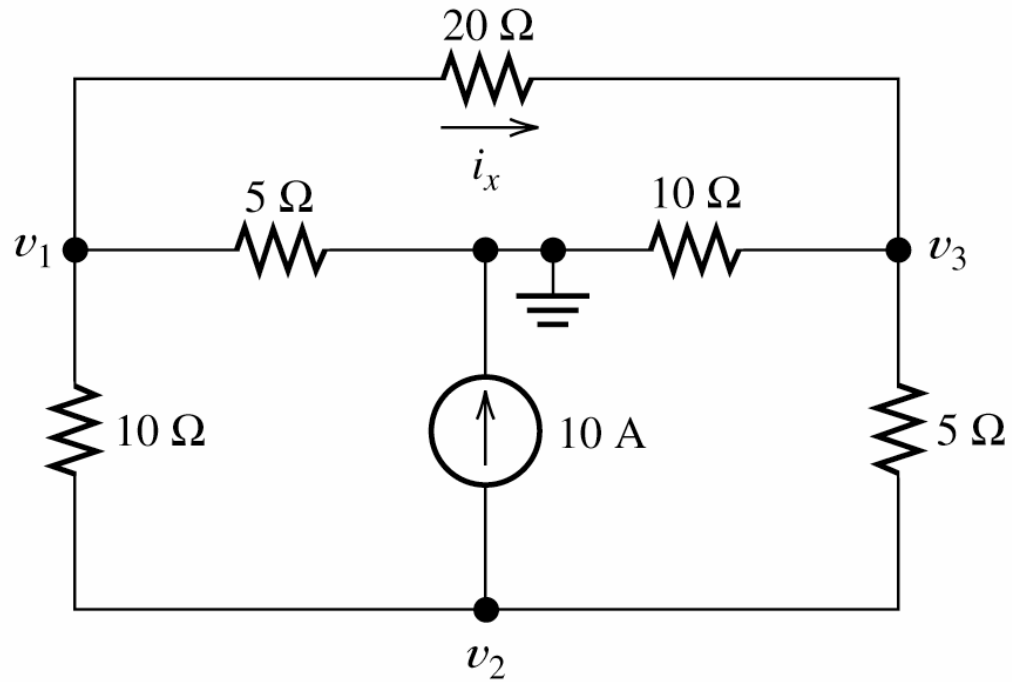

Figure 2.23 Circuit of Example 2.8 with a different choice for the reference node. See Exercise 2.9.

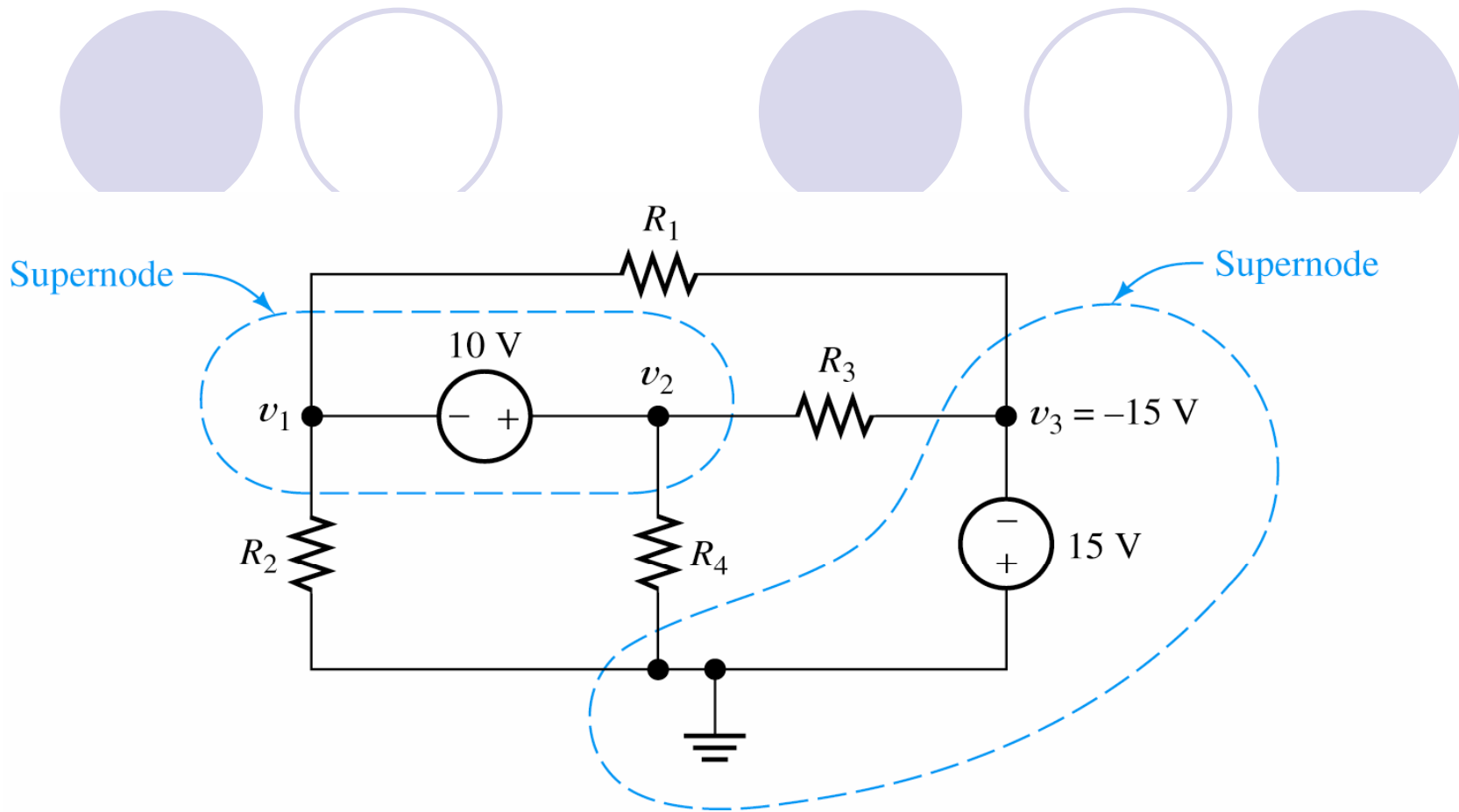

Figure 2.24 A supernode is formed by drawing a dashed line enclosing several nodes and any elements connected between them.



End 9/27/2006

Circuits with Voltage Sources



We obtain dependent equations if we use all of the nodes in a network to write KCL equations.

$$\frac{v_1}{R_2} + \frac{v_1 - (-15)}{R_1} + \frac{v_2}{R_4} + \frac{v_2 - (-15)}{R_3} = 0$$

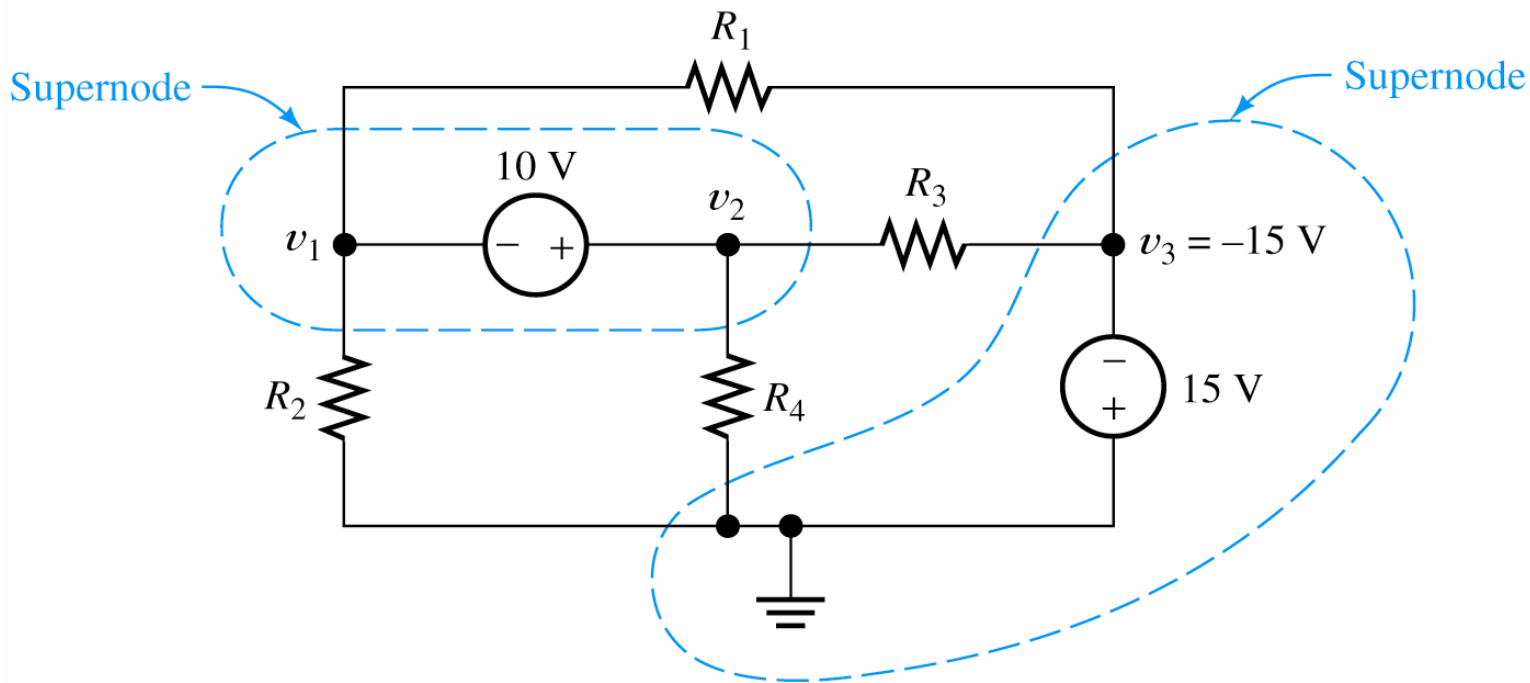

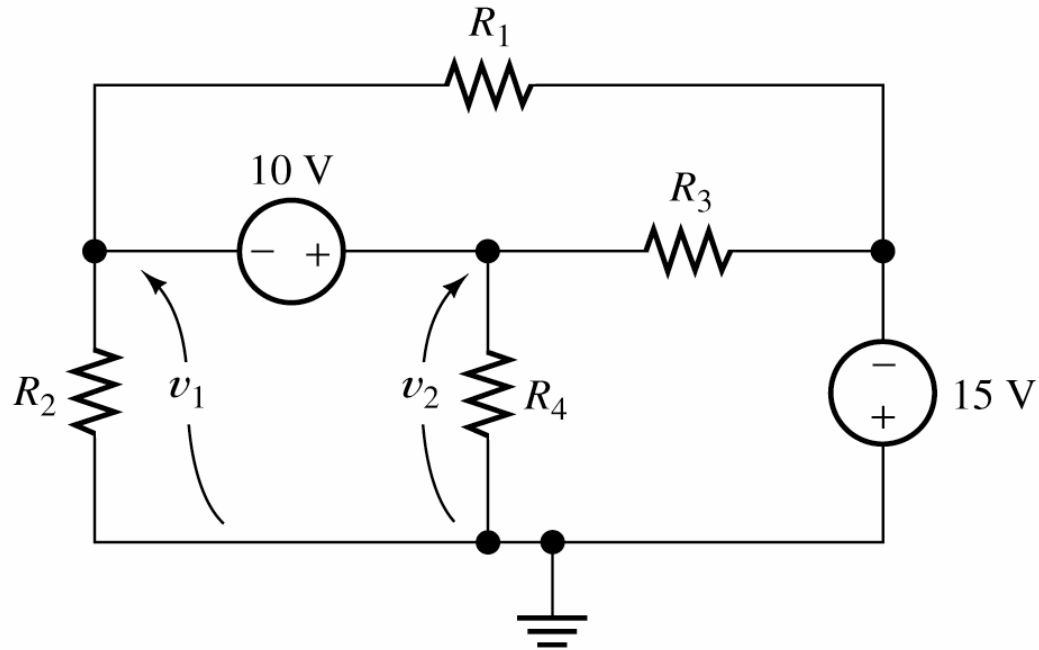
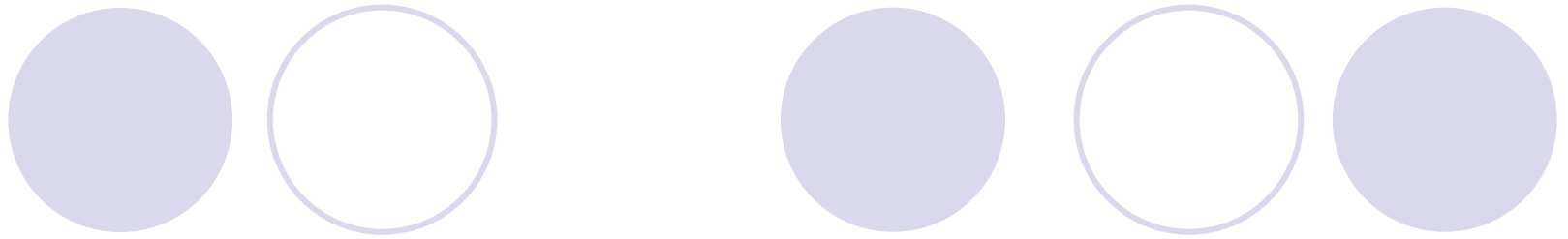

Figure 2.25 Node voltages v_1 and v_2 and the 10-V source form a closed loop to which KVL can be applied. (This is the same circuit as that of Figure 2.24.)

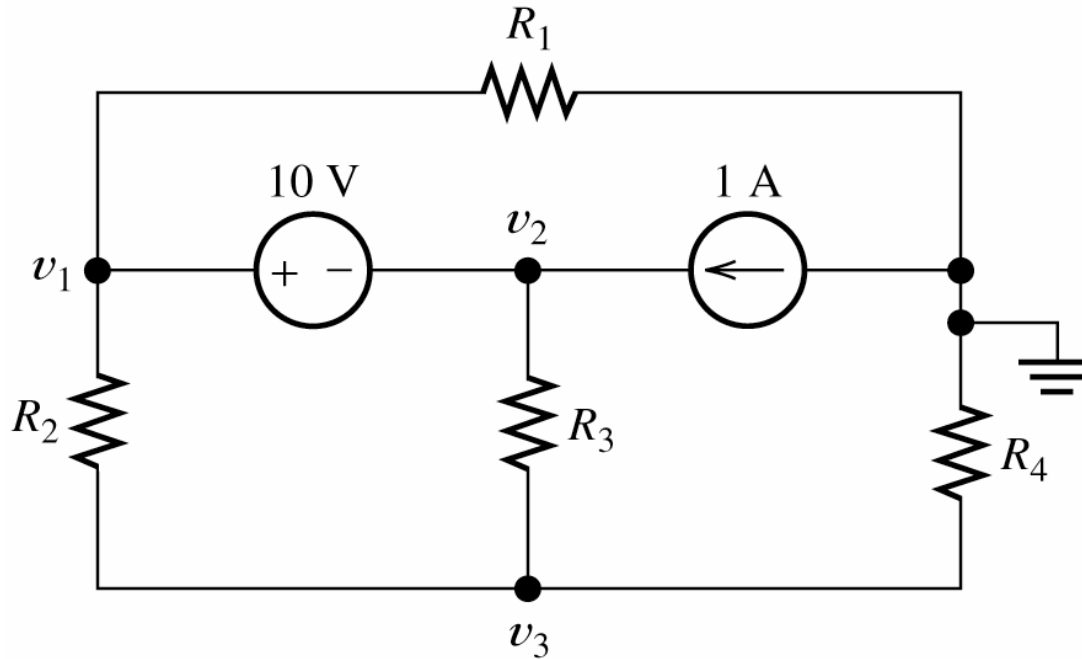
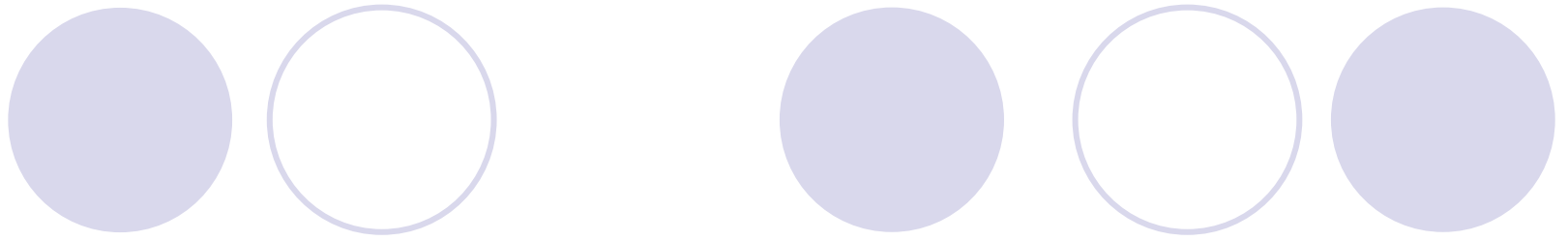
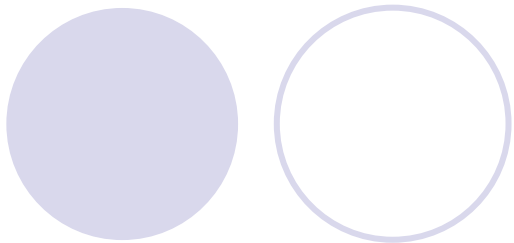
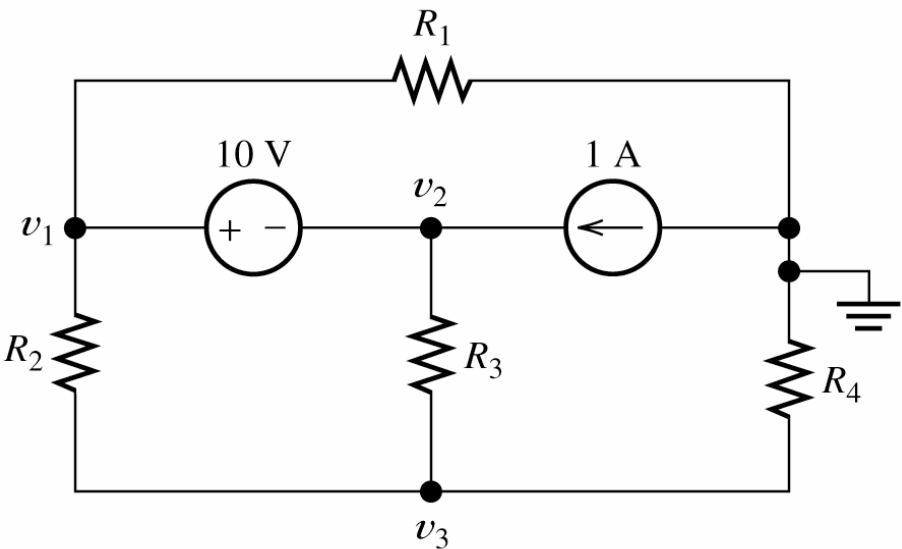

Figure 2.26 Circuit for Exercise 2.11.



$$-v_1 + 10 + v_2 = 0$$



$$\frac{v_1}{R_1} + \frac{v_1 - v_3}{R_2} + \frac{v_2 - v_3}{R_3} = 1$$

$$\frac{v_3 - v_1}{R_2} + \frac{v_3 - v_2}{R_3} + \frac{v_3}{R_4} = 0$$

$$\frac{v_1}{R_1} + \frac{v_3}{R_4} = 1$$

A decorative header consisting of five circles in a horizontal row. From left to right, the colors are: light purple, white with a light purple outline, light purple, white with a light purple outline, and light purple.

Node-Voltage Analysis with a Dependent Source

First, we write KCL equations at each node, including the current of the controlled source just as if it were an ordinary current source.

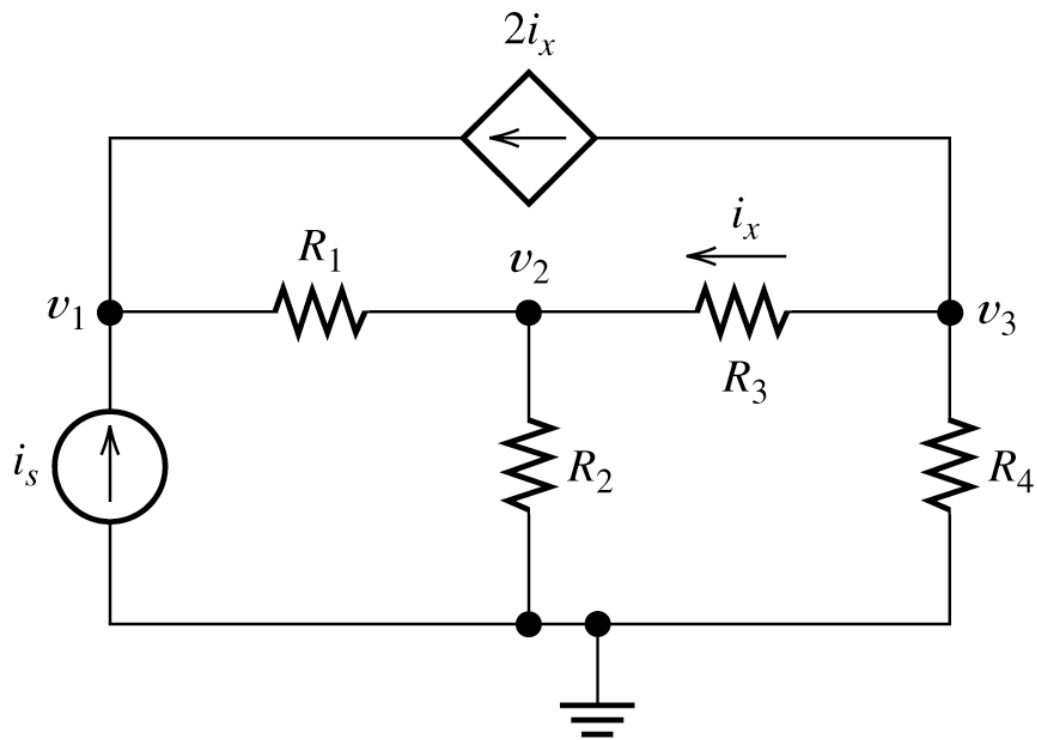
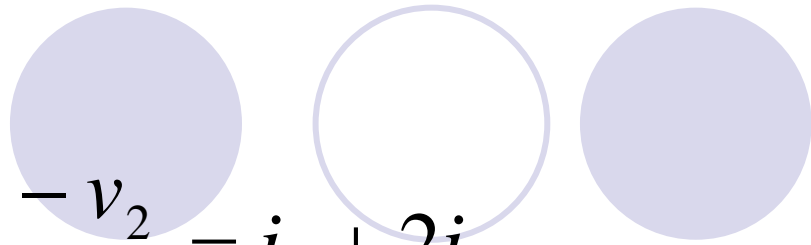
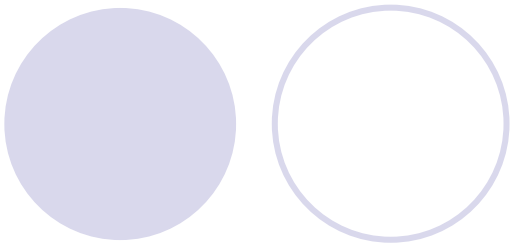

Figure 2.27 Circuit containing a current-controlled current source. See Example 2.9.



$$\frac{v_1 - v_2}{R_1} = i_s + 2i_x$$

$$\frac{v_2 - v_1}{R_1} + \frac{v_2}{R_2} + \frac{v_2 - v_3}{R_3} = 0$$

$$\frac{v_3 - v_2}{R_3} + \frac{v_3}{R_4} + 2i_x = 0$$

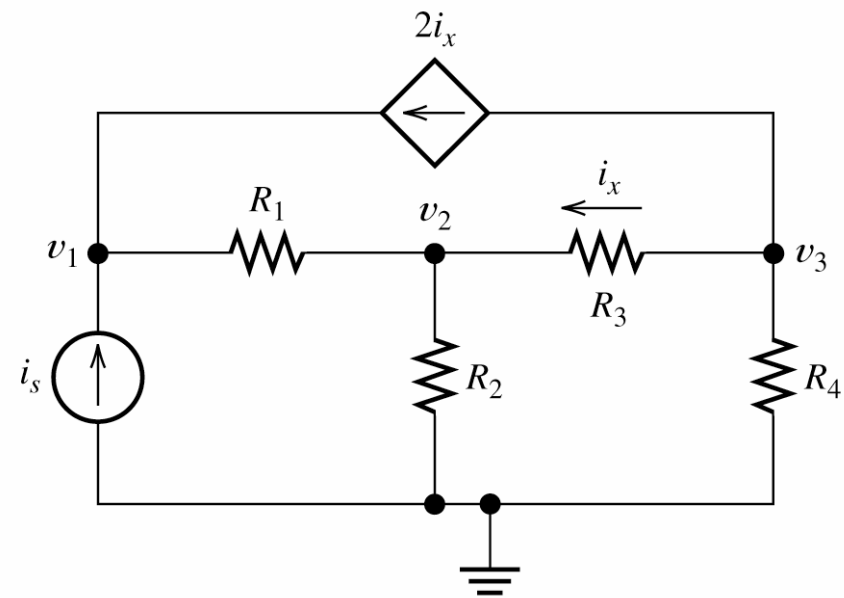

Next, we find an expression for the controlling variable i_x in terms of the node voltages.

$$i_x = \frac{v_3 - v_2}{R_3}$$

Substitution yields

$$\frac{v_1 - v_2}{R_1} = i_s + 2 \frac{v_3 - v_2}{R_3}$$

$$\frac{v_2 - v_1}{R_1} + \frac{v_2}{R_2} + \frac{v_2 - v_3}{R_3} = 0$$

$$\frac{v_3 - v_2}{R_3} + \frac{v_3}{R_4} + 2 \frac{v_3 - v_2}{R_3} = 0$$

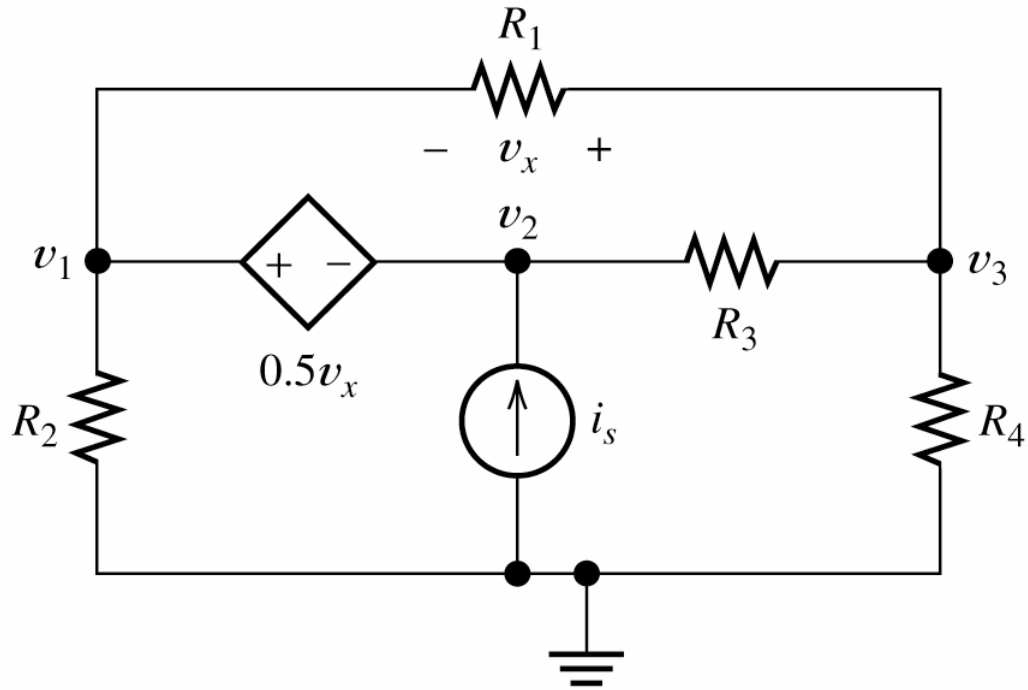
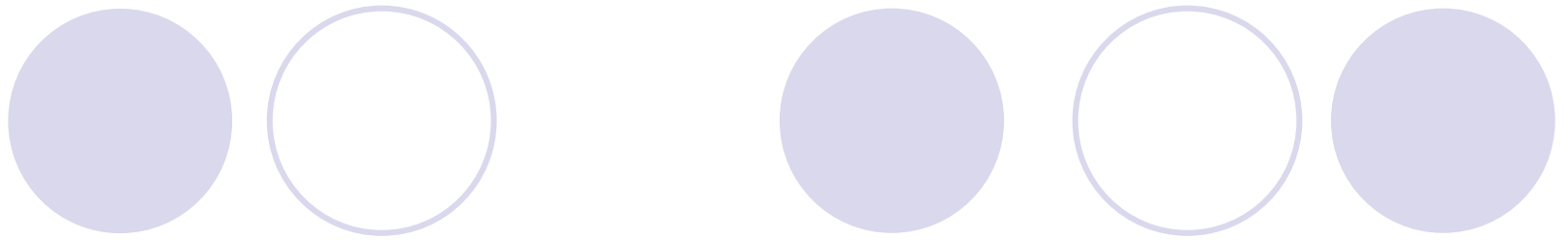
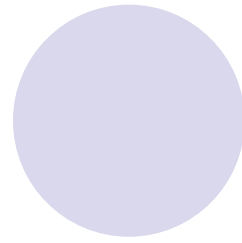
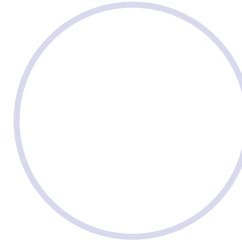
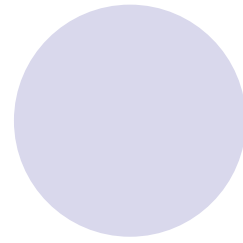
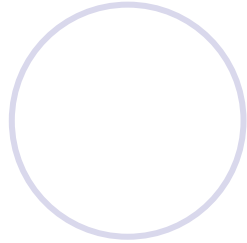
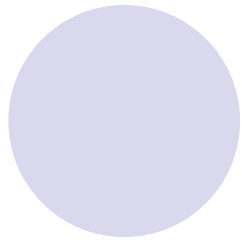

Figure 2.28 Circuit containing a voltage-controlled voltage source. See Example 2.10.

A decorative header consisting of five circles in a row. From left to right: a solid light purple circle, an outlined light purple circle, a solid light purple circle, an outlined light purple circle, and a solid light purple circle.

Node-Voltage Analysis

1. Select a reference node and assign variables for the unknown node voltages. If the reference node is chosen at one end of an independent voltage source, one node voltage is known at the start, and fewer need to be computed.



2. Write network equations. First, use KCL to write current equations for nodes and supernodes. Write as many current equations as you can without using all of the nodes. Then if you do not have enough equations because of voltage sources connected between nodes, use KVL to write additional equations.

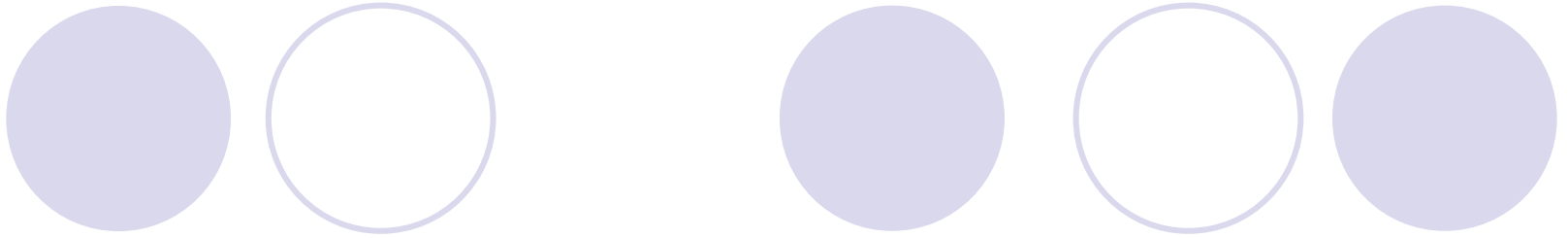

- 3.** If the circuit contains dependent sources, find expressions for the controlling variables in terms of the node voltages. Substitute into the network equations, and obtain equations having only the node voltages as unknowns.



4. Put the equations into standard form and solve for the node voltages.

5. Use the values found for the node voltages to calculate any other currents or voltages of interest.

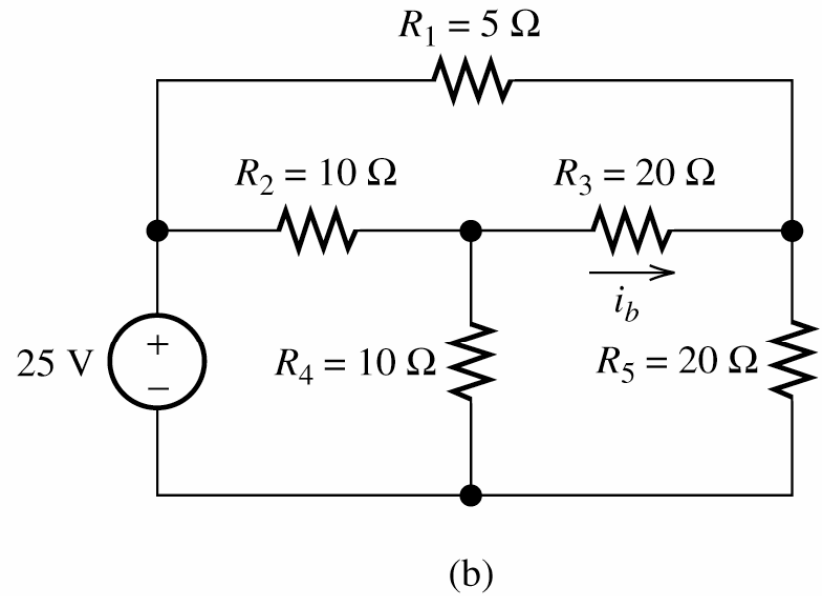
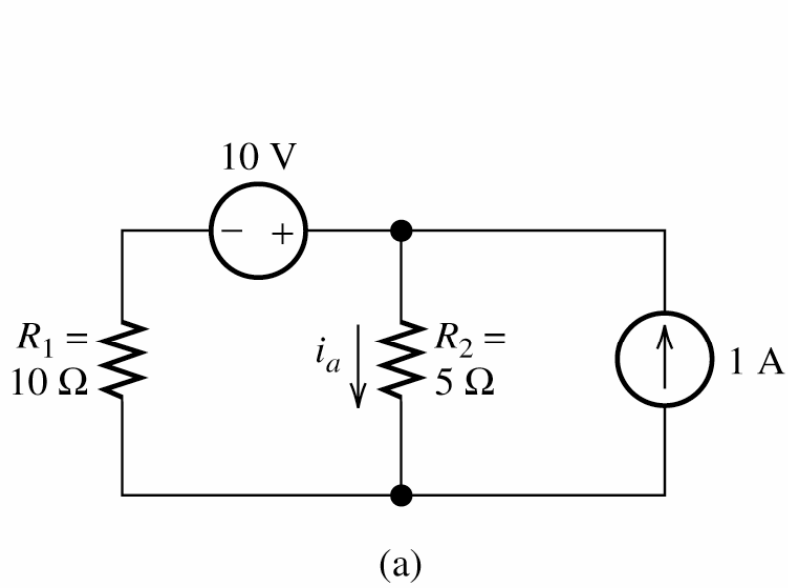
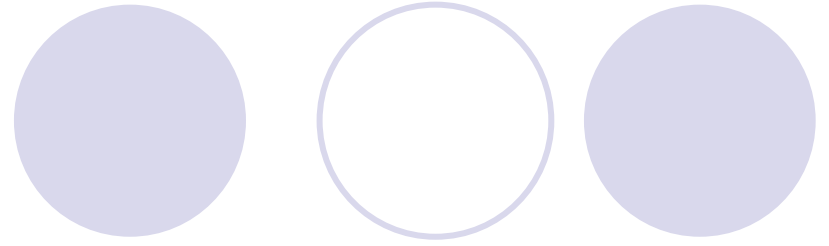
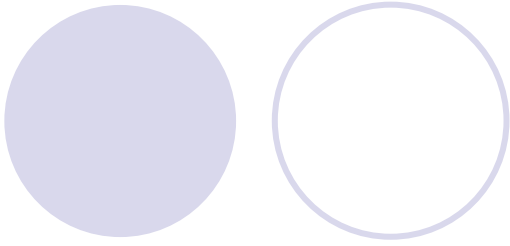

Figure 2.29 Circuits for Exercise 2.12.

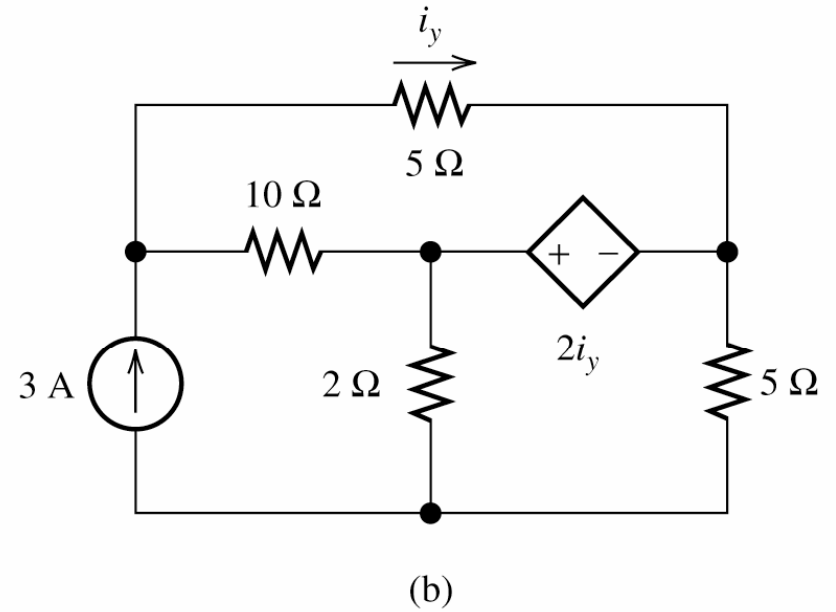
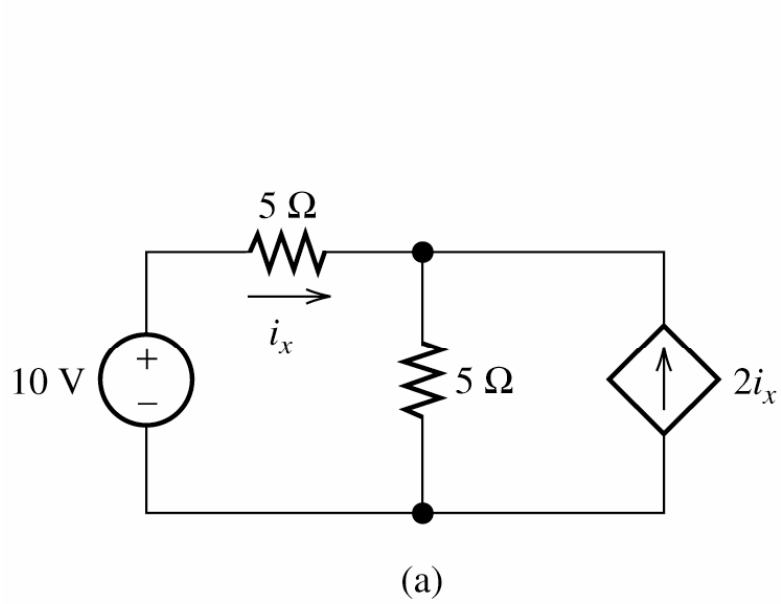
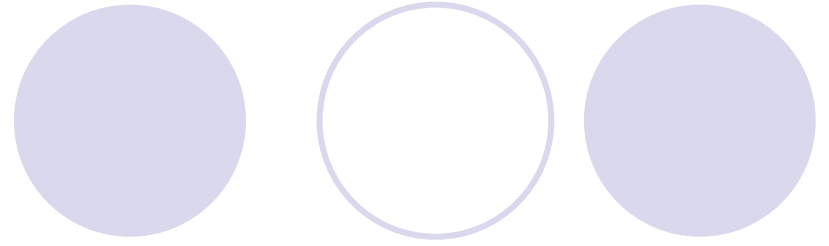
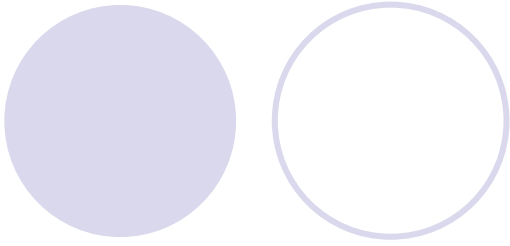
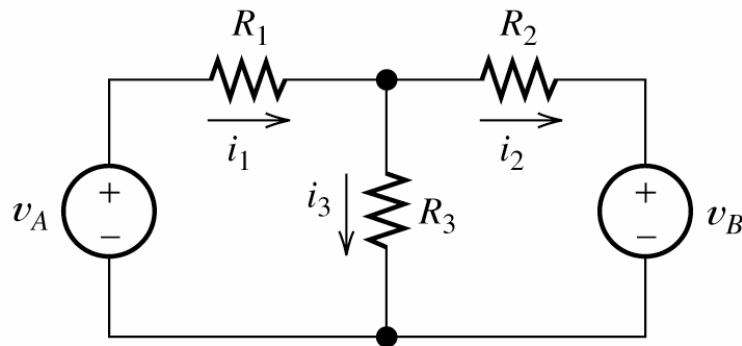
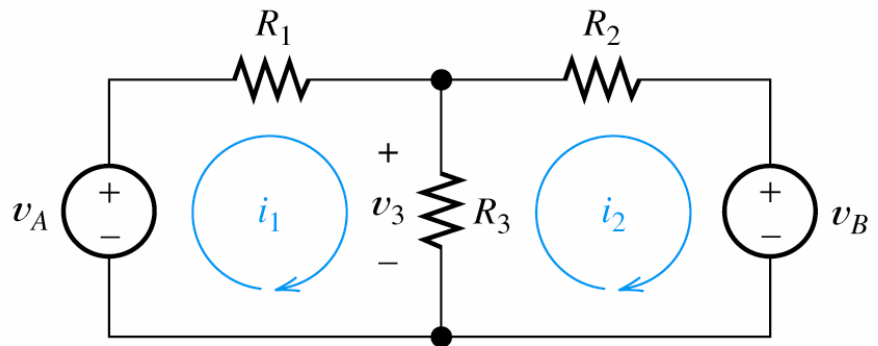

Figure 2.30 Circuits for Exercise 2.13.

Mesh Current Analysis



(a) Circuit with branch currents



(b) Circuit with mesh currents

Figure 2.31 Circuit for illustrating the mesh-current method of circuit analysis.

Choosing the Mesh Currents



When several mesh currents flow through one element, we consider the current in that element to be the algebraic sum of the mesh currents.

Sometimes it is said that the mesh currents are defined by “soaping the window panes.”

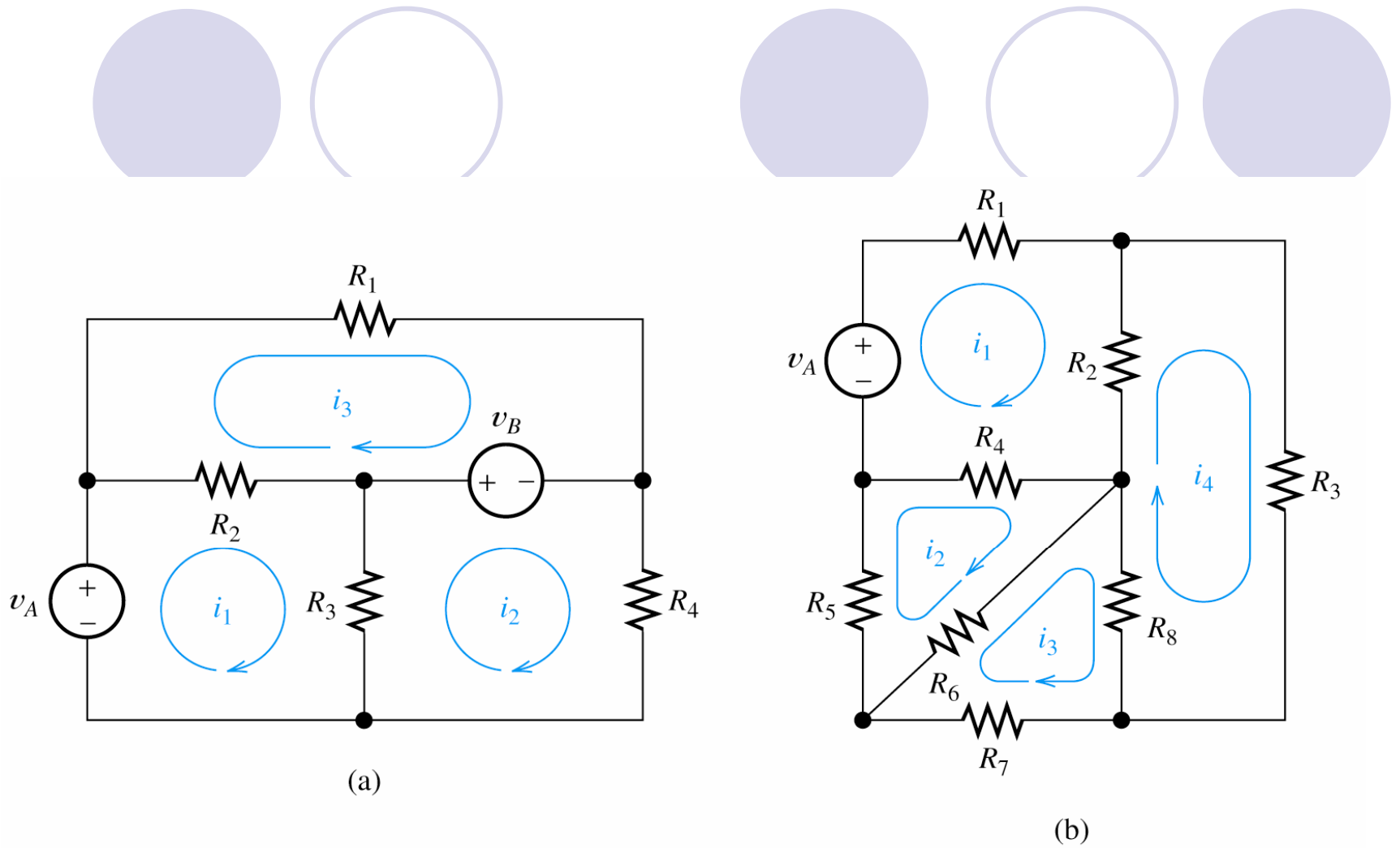

Figure 2.32 Two circuits and their mesh-current variables.



Writing Equations to Solve for Mesh Currents

If a network contains only resistances and independent voltage sources, we can write the required equations by following each current around its mesh and applying KVL.

Using this pattern for mesh 1 of Figure 2.32(a), we have

$$R_2(i_1 - i_s) + R_3(i_1 - i_2) - v_A = 0$$

For mesh 2, we obtain

$$R_3(i_2 - i_1) + R_4 i_2 + v_B = 0$$

For mesh 3, we have

$$R_2(i_3 - i_1) + R_1 i_3 - v_B = 0$$



In Figure 2.32(b)

$$R_1 i_1 + R_2 (i_1 - i_4) + R_4 (i_1 - i_2) - v_A = 0$$

$$R_5 i_2 + R_4 (i_2 - i_1) + R_6 (i_2 - i_3) = 0$$

$$R_7 i_3 + R_6 (i_3 - i_2) + R_8 (i_3 - i_4) = 0$$

$$R_3 i_4 + R_2 (i_4 - i_1) + R_8 (i_4 - i_3) = 0$$

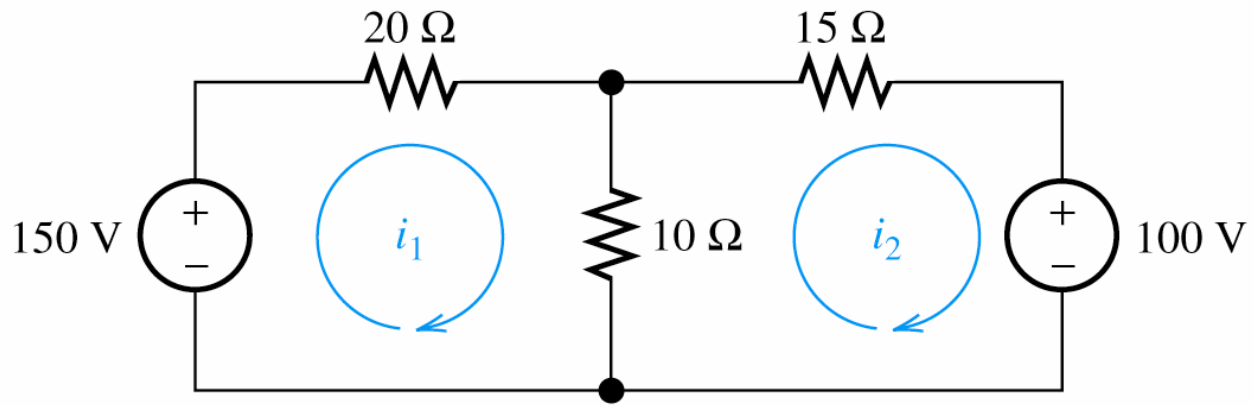

Figure 2.33 Circuit of Example 2.12.

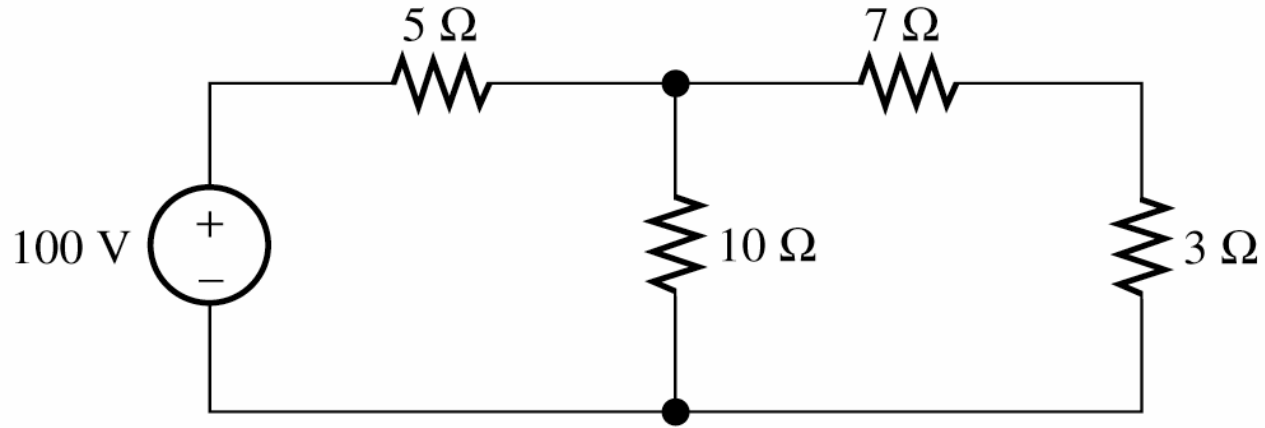
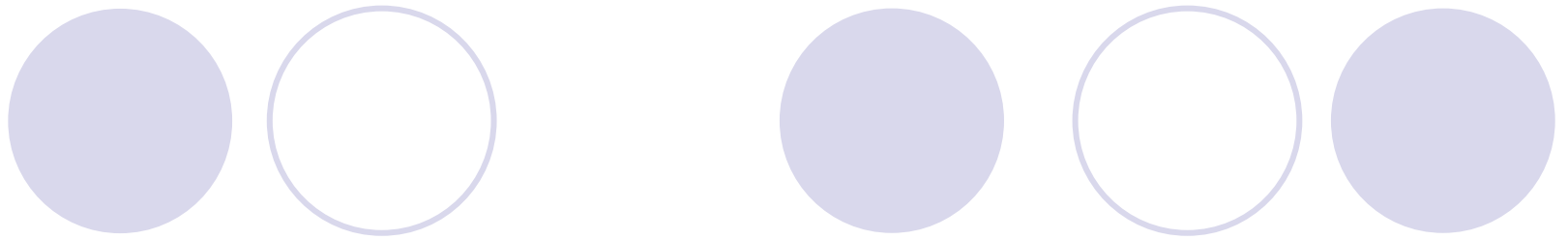

Figure 2.34 Circuit of Exercise 2.16.

Mesh Currents in Circuits Containing Current Sources

A common mistake made by beginning students is to assume that the voltages across current sources are zero. In Figure 2.35, we have:

$$i_1 = 2A$$

$$10(i_2 - i_1) + 5i_2 + 10 = 0$$

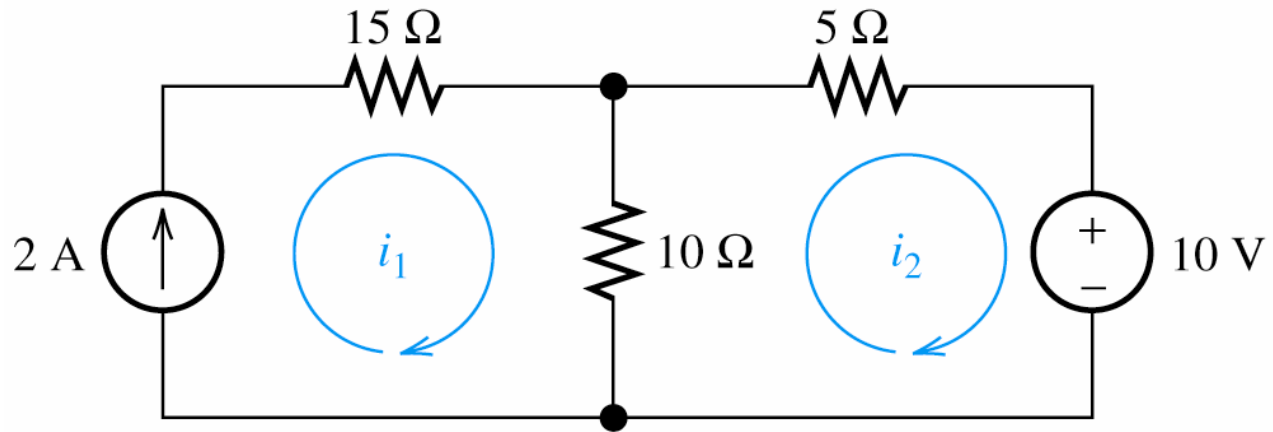

Figure 2.35 In this circuit, we have $i_1 = 2$ A.

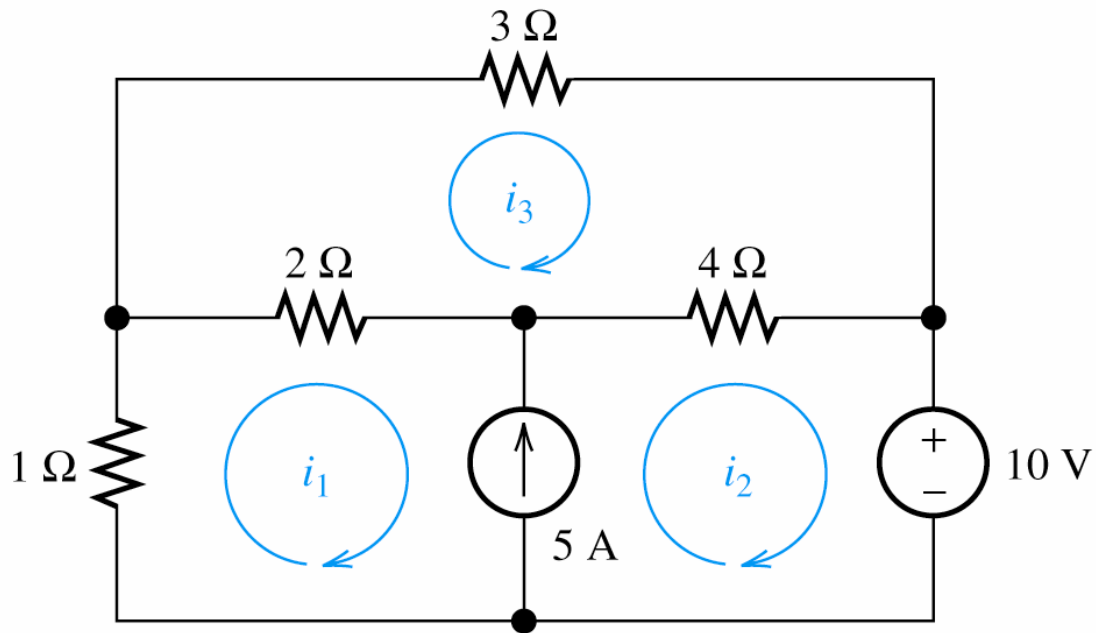



Figure 2.36 A circuit with a current source common to two meshes.



Combine meshes 1 and 2 into a **supermesh**. In other words, we write a KVL equation around the periphery of meshes 1 and 2 combined.

$$i_1 + 2(i_1 - i_3) + 4(i_2 - i_3) + 10 = 0$$

Mesh 3:

$$3i_3 + 4(i_3 - i_2) + 2(i_3 - i_1) = 0$$

$$i_2 - i_1 = 5$$

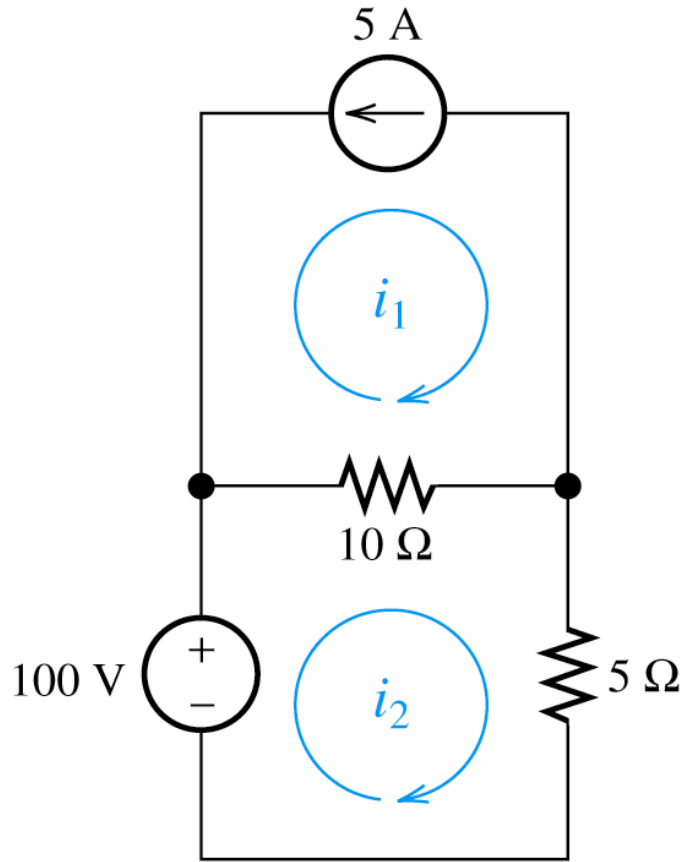

Figure 2.37 The circuit for Exercise 2.18.

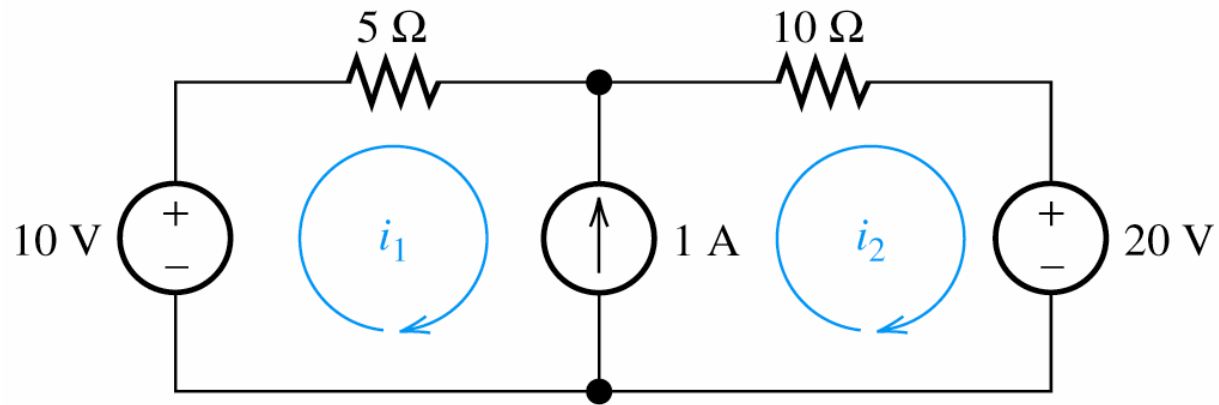

Figure 2.38 The circuit for Exercise 2.19.

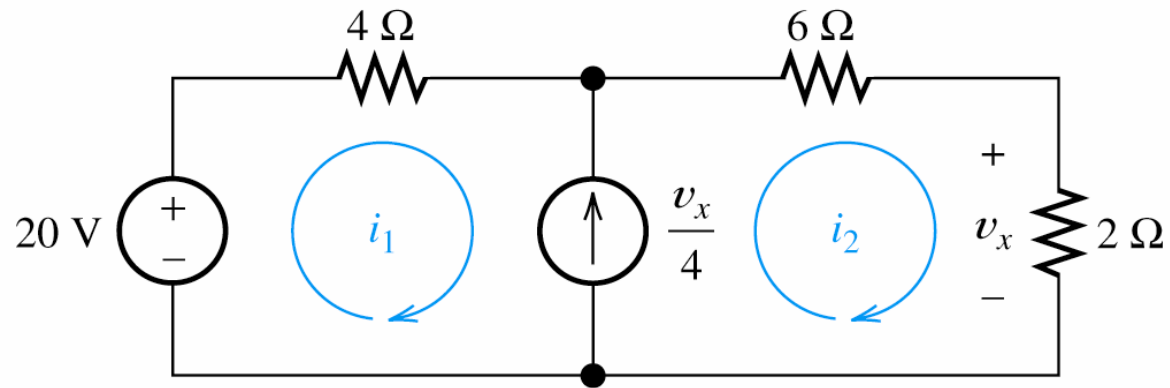
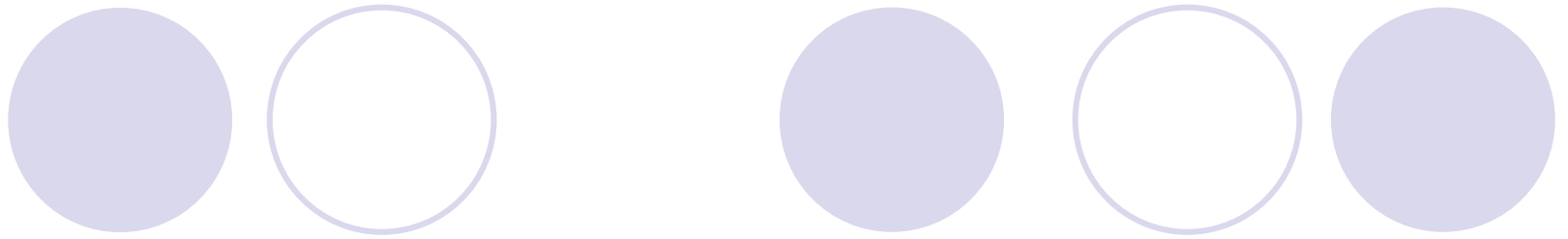
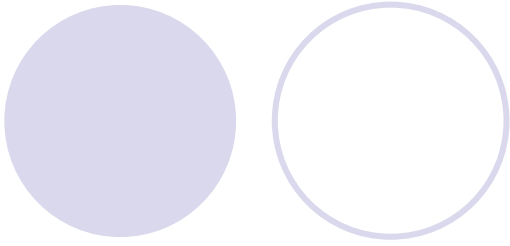
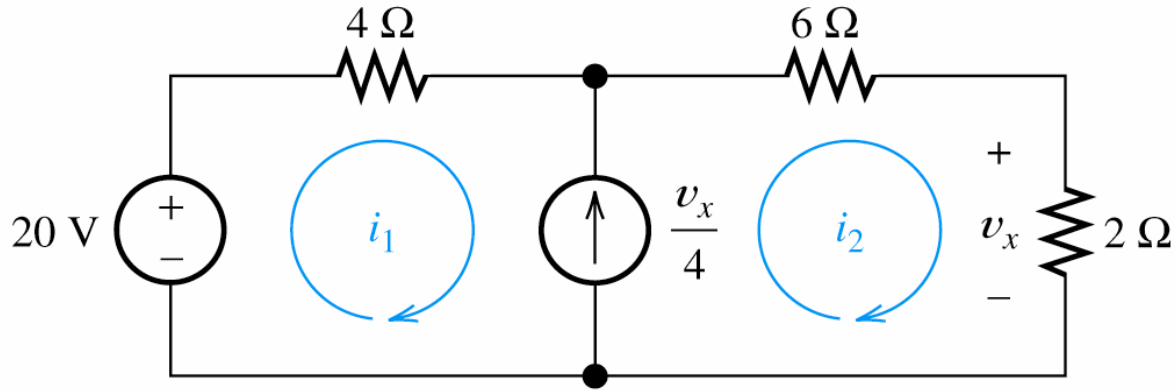

Figure 2.39 A circuit with a voltage-controlled current source. See Example 2.13.



$$-20 + 4i_1 + 6i_2 + 2i_2 = 0$$



$$\frac{v_x}{4} = i_2 - i_1$$

$$v_x = 2i_2$$



Mesh-Current Analysis

1. If necessary, redraw the network without crossing conductors or elements. Then define the mesh currents flowing around each of the open areas defined by the network. For consistency, we usually select a clockwise direction for each of the mesh currents, but this is not a requirement.

2. Write network equations, stopping after the number of equations is equal to the number of mesh currents. First, use KVL to write voltage equations for meshes that do not contain current sources. Next, if any current sources are present, write expressions for their currents in terms of the mesh currents. Finally, if a current source is common to two meshes, write a KVL equation for the supermesh.

A decorative header consisting of five circles in a horizontal row. From left to right, the colors are: solid light purple, hollow light purple outline, solid light purple, hollow light purple outline, and solid light purple.

3. If the circuit contains dependent sources, find expressions for the controlling variables in terms of the mesh currents. Substitute into the network equations, and obtain equations having only the mesh currents as unknowns.



4. Put the equations into standard form. Solve for the mesh currents by use of determinants or other means.

5. Use the values found for the mesh currents to calculate any other currents or voltages of interest.

Thévenin Equivalent Circuits

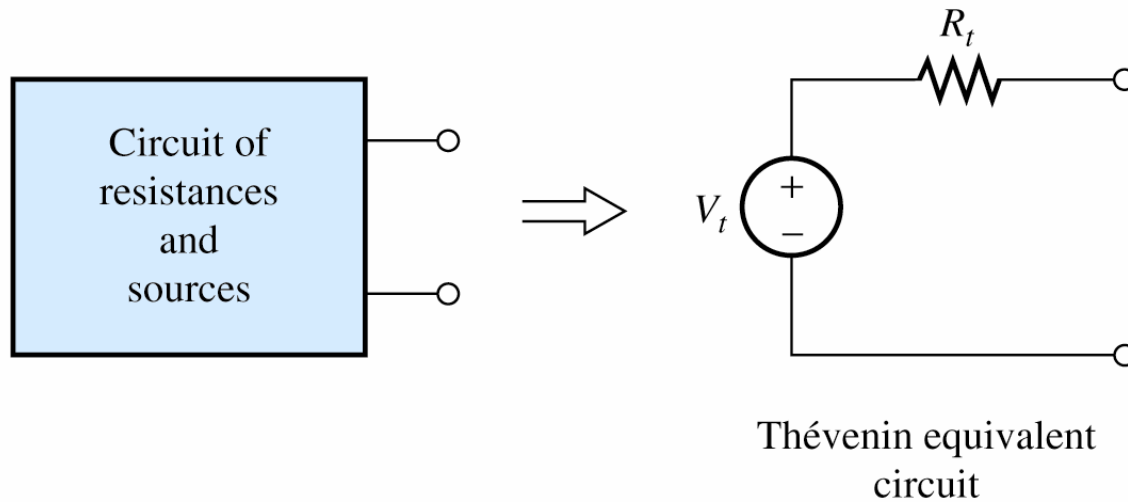

Figure 2.40 A two-terminal circuit consisting of resistances and sources can be replaced by a Thévenin equivalent circuit.

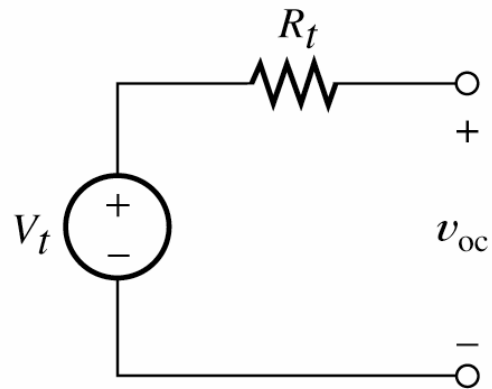
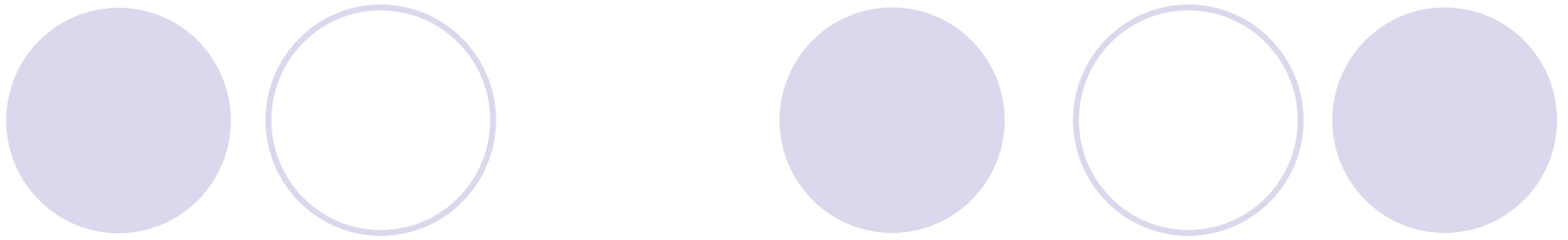

Figure 2.41 Thévenin equivalent circuit with open-circuited terminals. The open-circuit voltage v_{oc} is equal to the Thévenin voltage V_t .

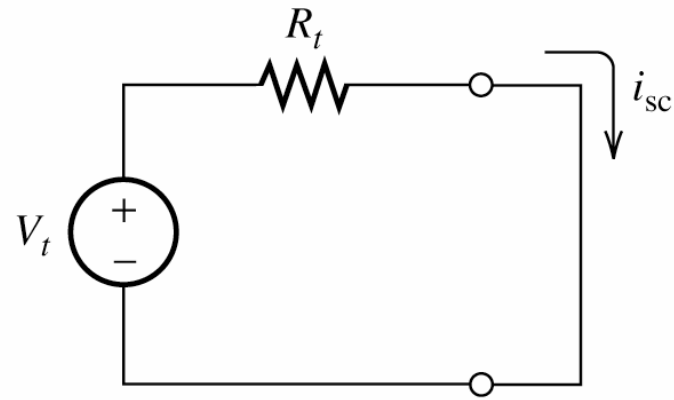
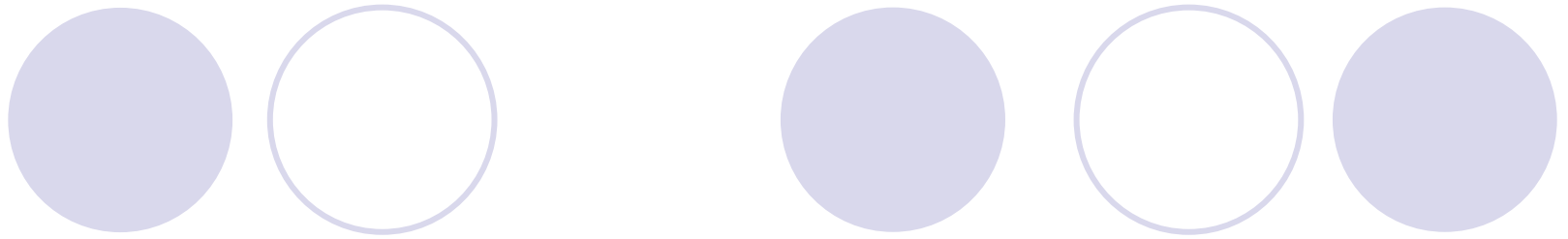
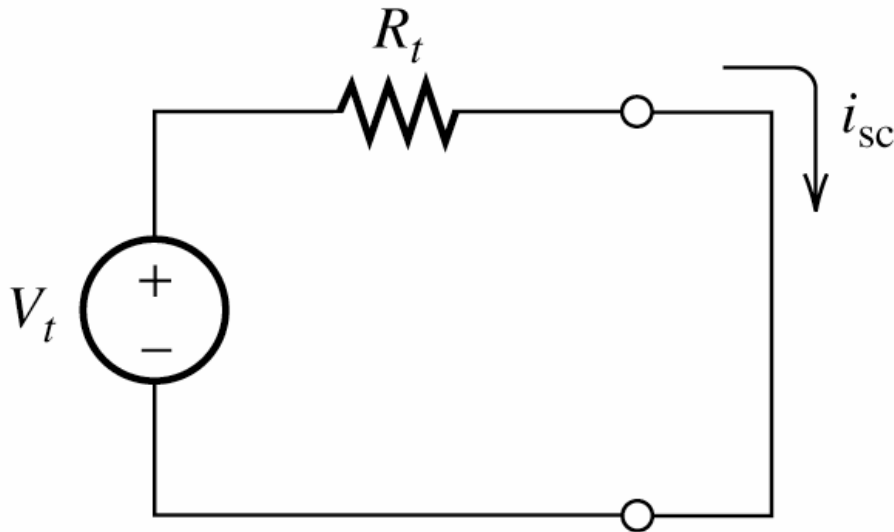

Figure 2.42 Thévenin equivalent circuit with short-circuited terminals. The short-circuit current is $i_{sc} = V_t/R_t$.

Thévenin Equivalent Circuits



$$V_t = v_{oc}$$

$$R_t = \frac{v_{oc}}{i_{sc}}$$

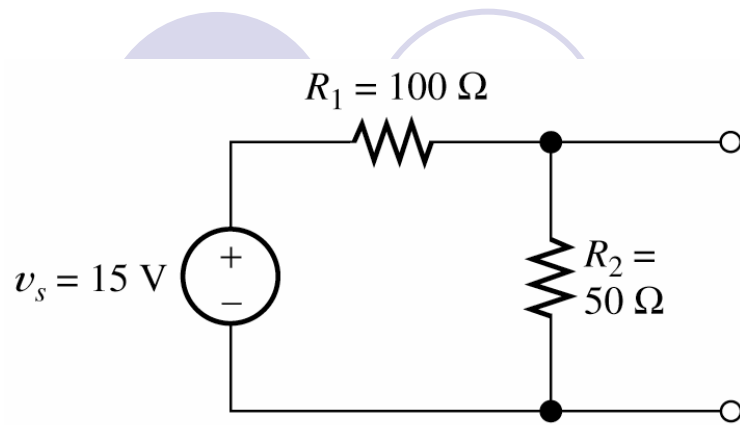

(a) Original circuit

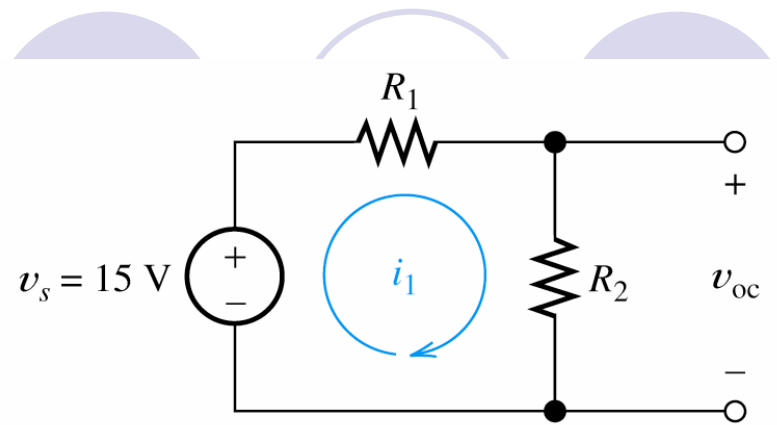

(b) Analysis with an open circuit

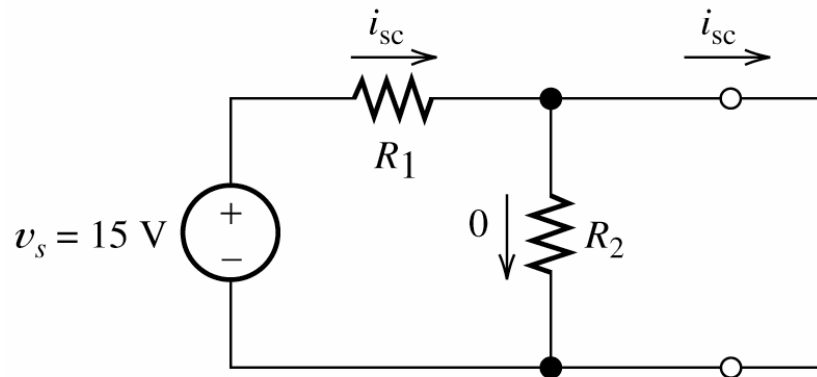

(c) Analysis with a short circuit

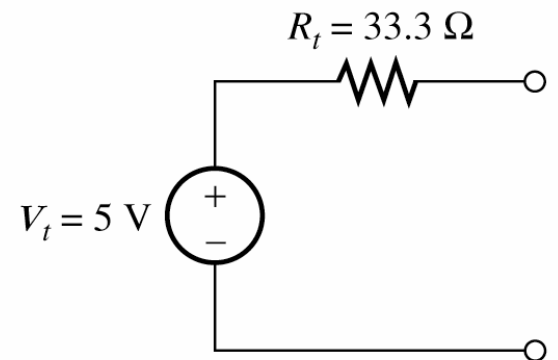

(d) Thévenin equivalent

Figure 2.43 Circuit for Example 2.14.

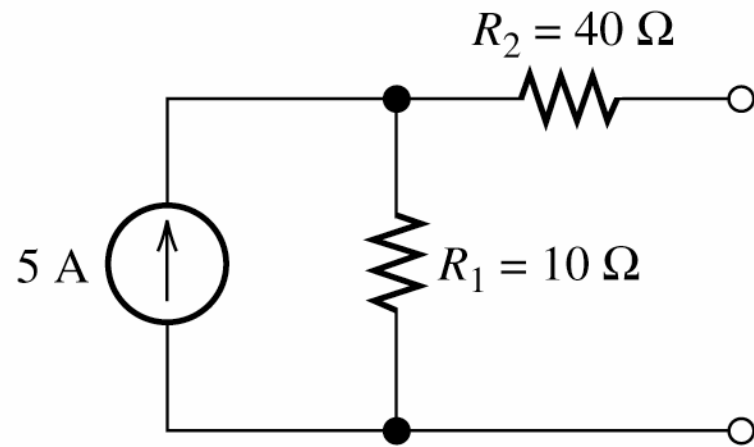
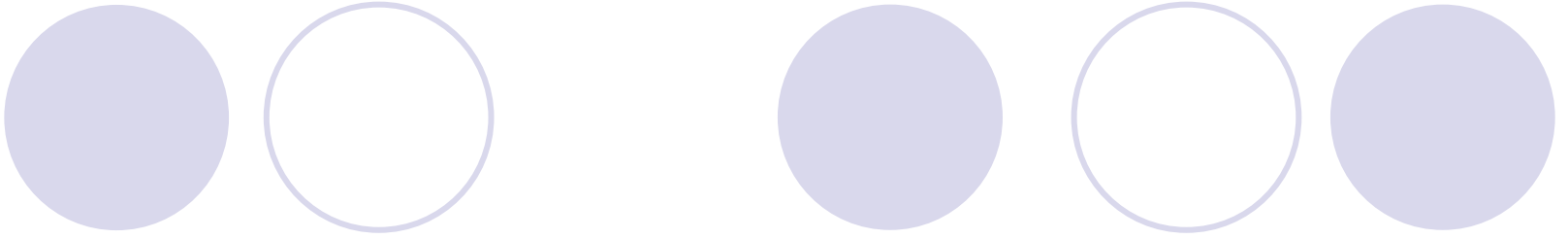
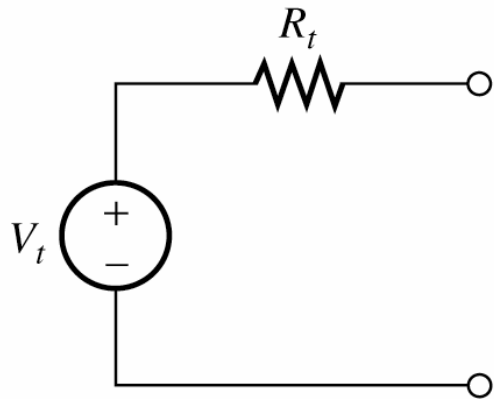
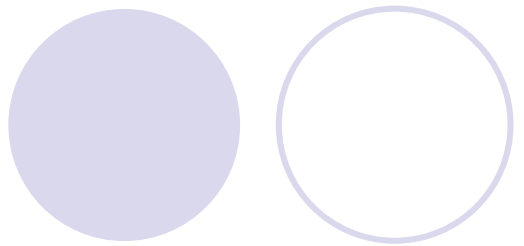

Figure 2.44 Circuit for Exercise 2.22.

Finding the Thévenin Resistance Directly

When zeroing a voltage source, it becomes a short circuit. When zeroing a current source, it becomes an open circuit.

We can find the Thévenin resistance by zeroing the sources in the original network and then computing the resistance between the terminals.



(a) Thévenin equivalent

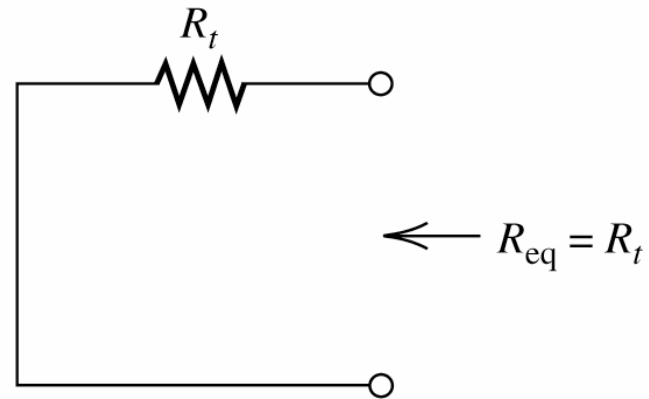
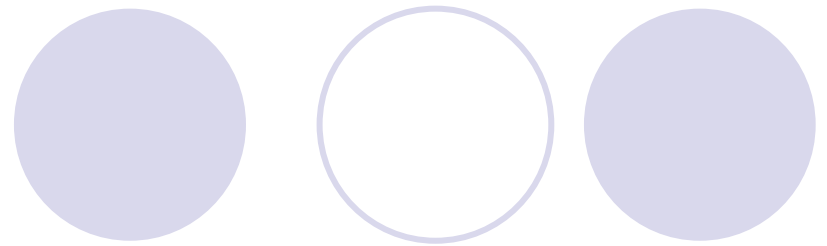

(b) Thévenin equivalent with its source zeroed

Figure 2.45 When the source is zeroed, the resistance seen from the circuit terminals is equal to the Thévenin resistance.

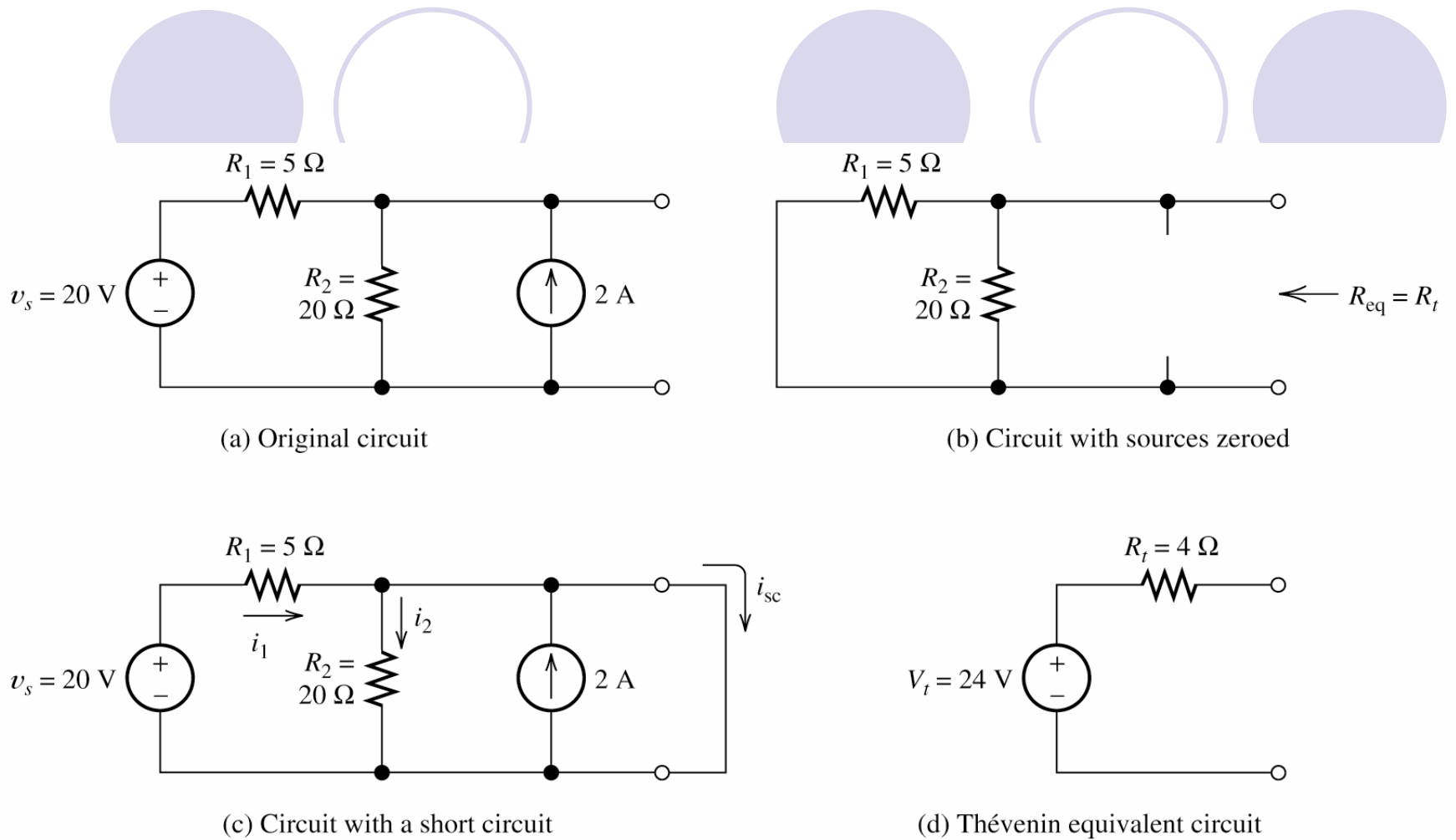

Figure 2.46 Circuit for Example 2.15.

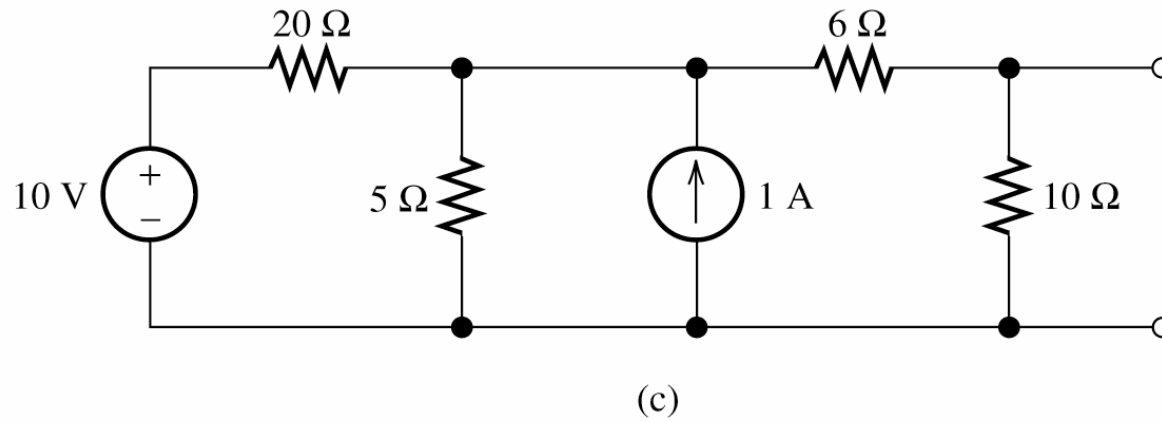
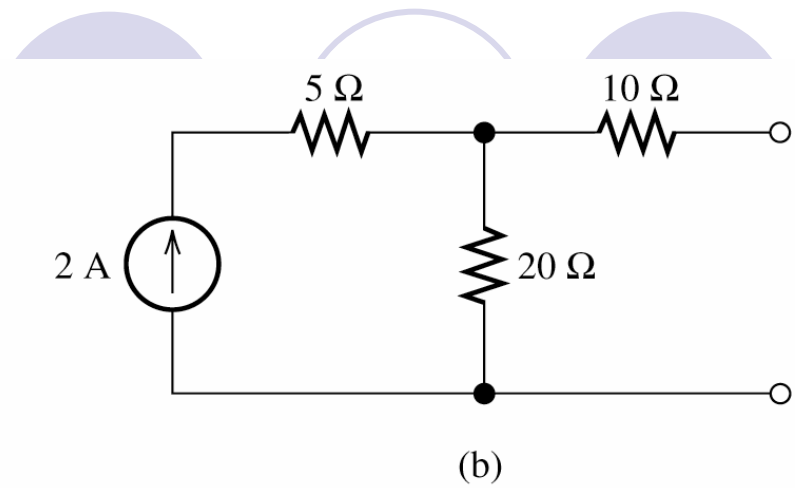
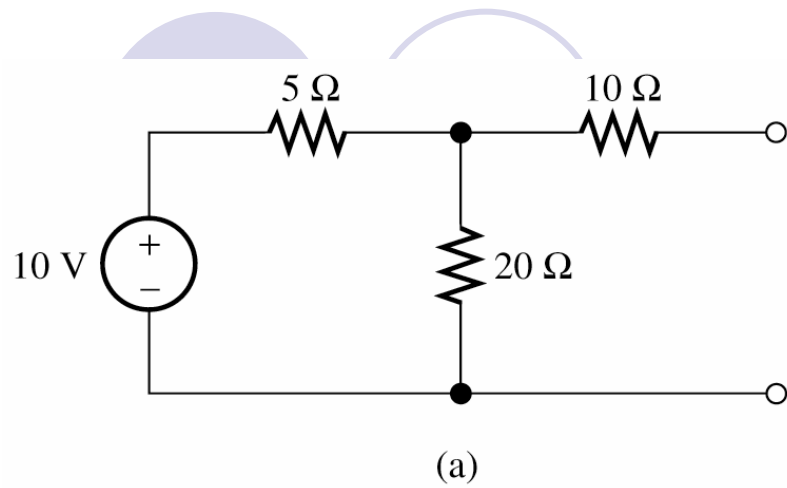
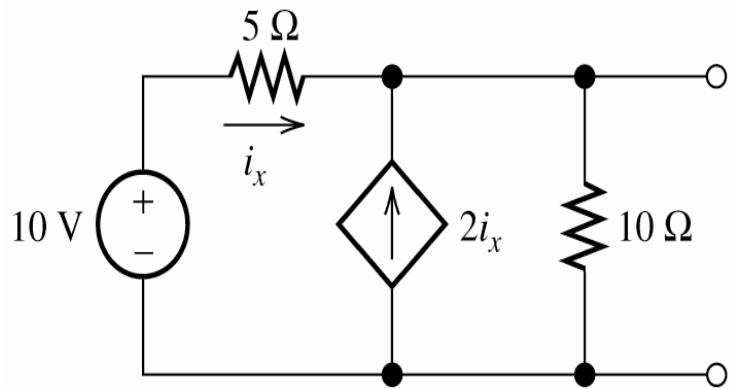
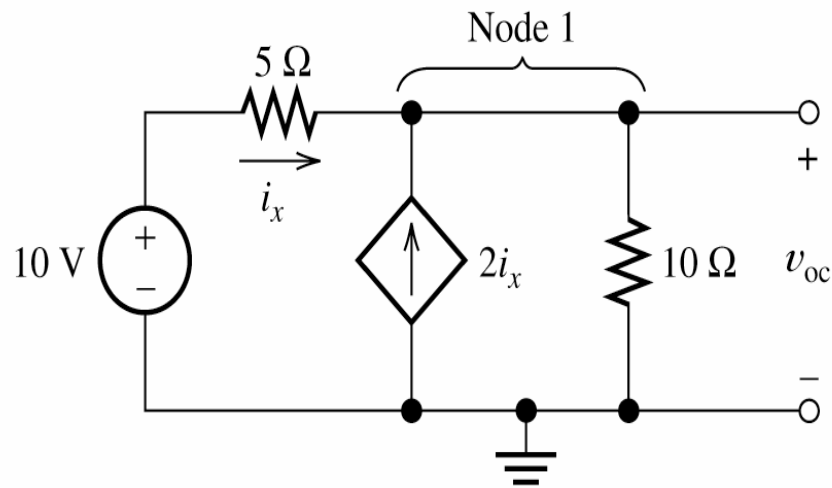

Figure 2.47 Circuits for Exercise 2.24.



(a) Original circuit



(b) Circuit with an open circuit

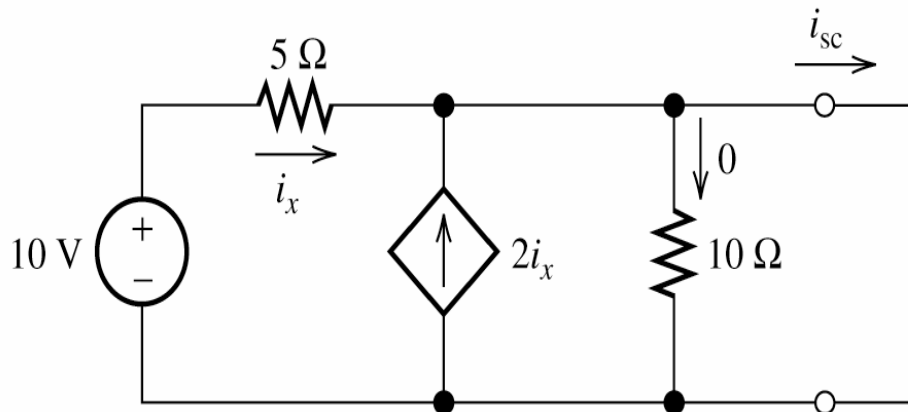

(c) Circuit with a short circuit

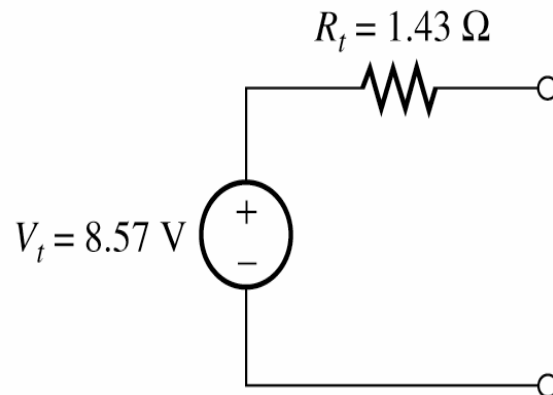

(d) Thévenin equivalent

Figure 2.48 Circuit for Example 2.16.

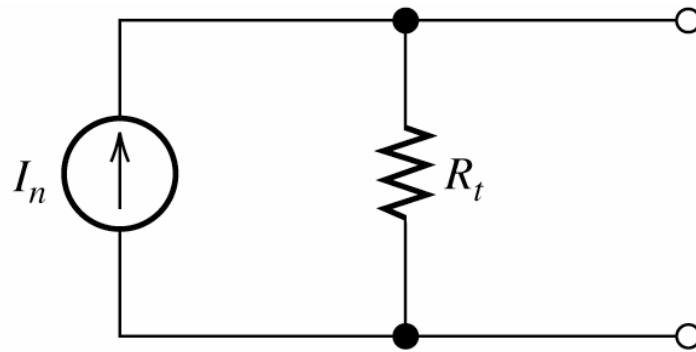

Figure 2.49 The Norton equivalent circuit consists of an independent current source I_n in parallel with the Thévenin resistance R_t .

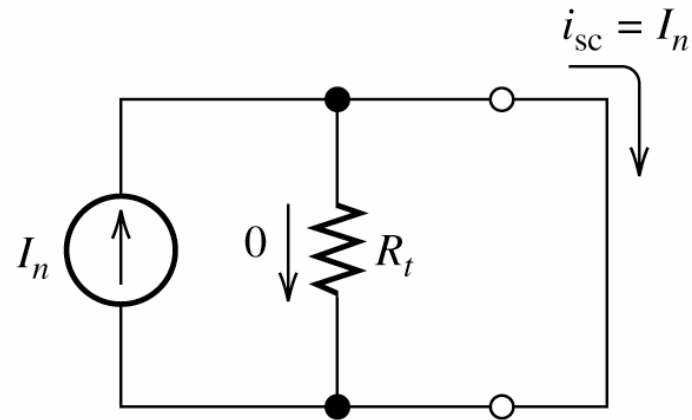
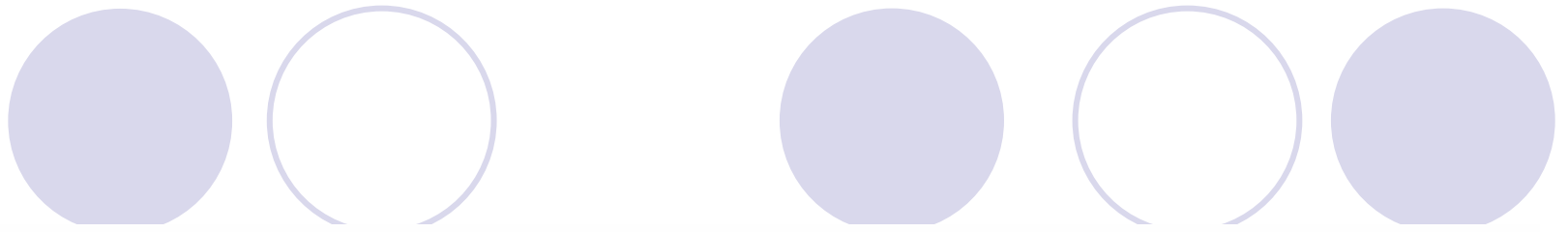

Figure 2.50 The Norton equivalent circuit with a short circuit across its terminals.

Step-by-step Thévenin/Norton-Equivalent-Circuit Analysis

1. Perform two of these:

a. Determine the open-circuit voltage $V_t = V_{oc}$.

b. Determine the short-circuit current $I_n = I_{sc}$.

c. Zero the sources and find the Thévenin resistance R_t looking back into the terminals.



2. Use the equation $V_t = R_t I_n$ to compute the remaining value.

3. The Thévenin equivalent consists of a voltage source V_t in series with R_t .

4. The Norton equivalent consists of a current source I_n in parallel with R_t .

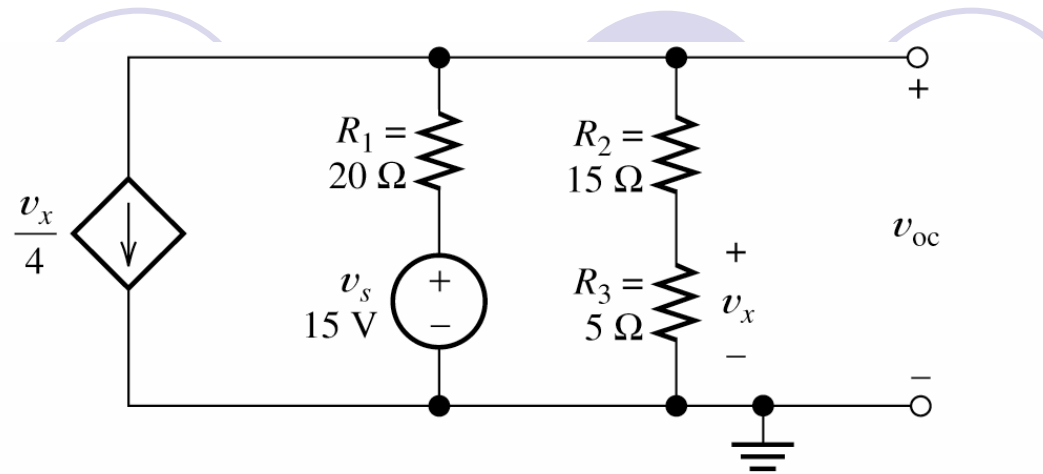

(a) Original circuit under open-circuit conditions

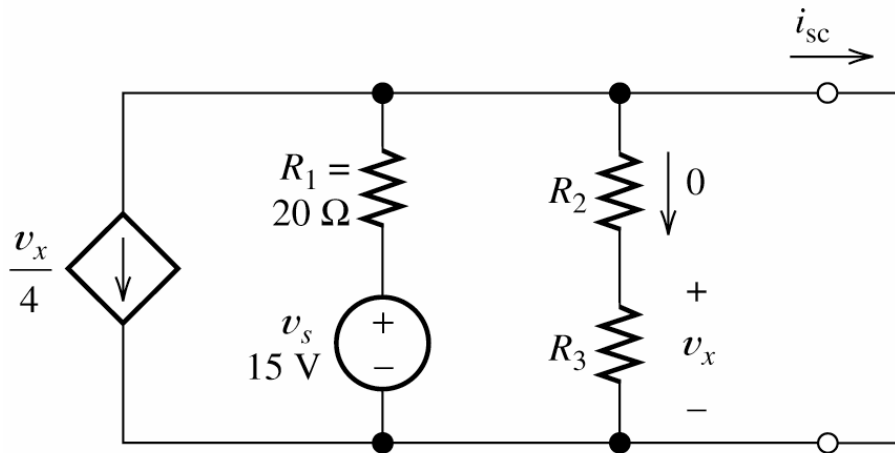

(b) Circuit with a short circuit

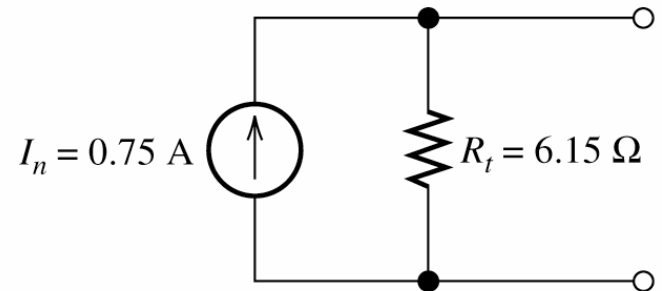

(c) Norton equivalent circuit

Figure 2.51 Circuit of Example 2.17.

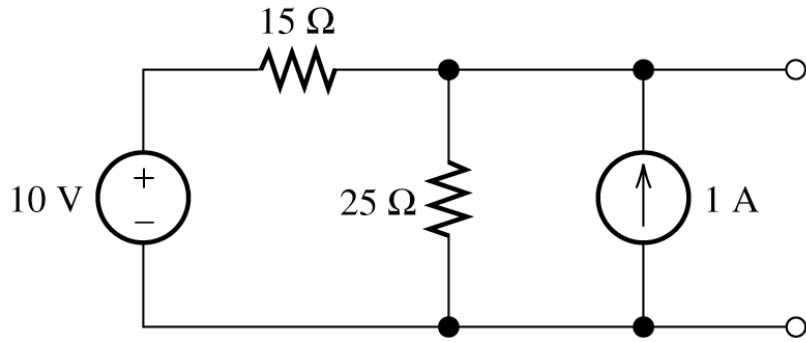
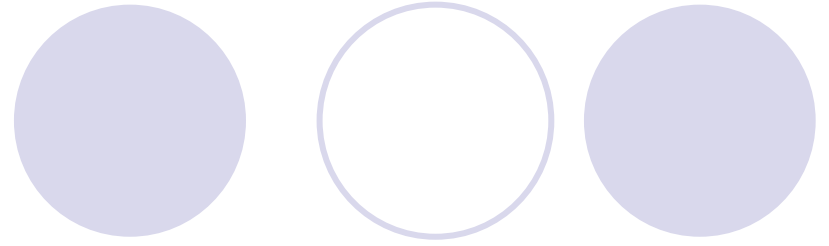
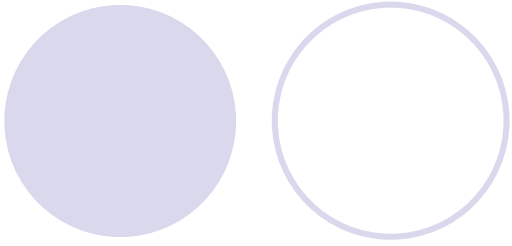

(a)

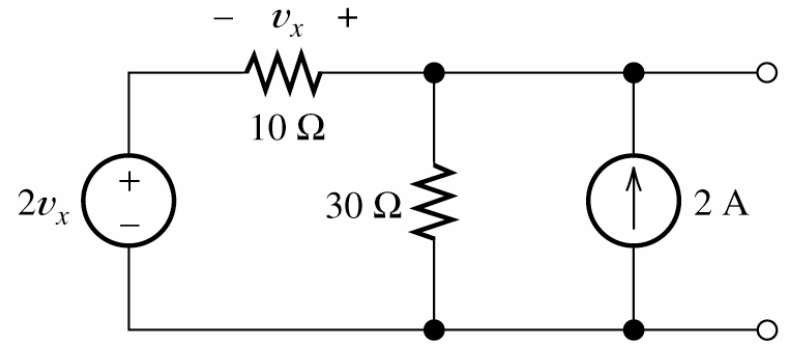

(b)

Figure 2.52 Circuits for Exercise 2.25.

Source Transformations

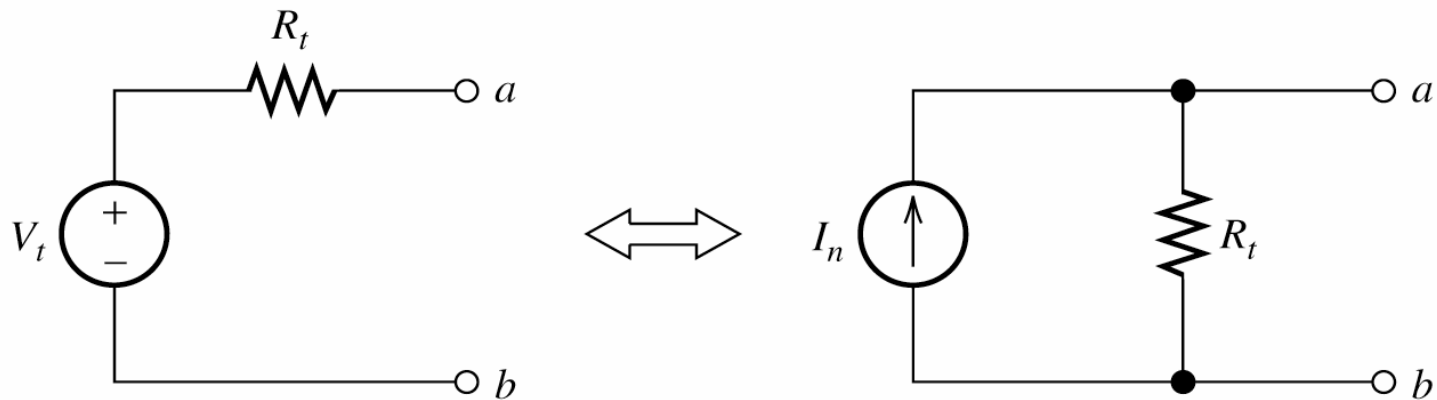
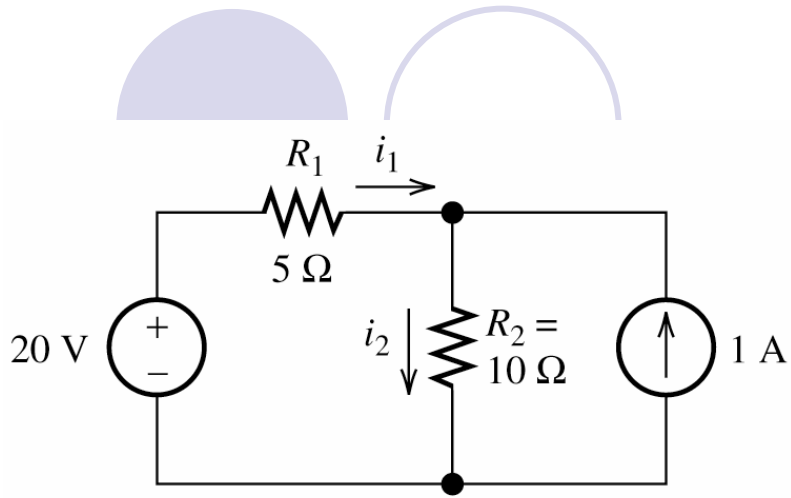
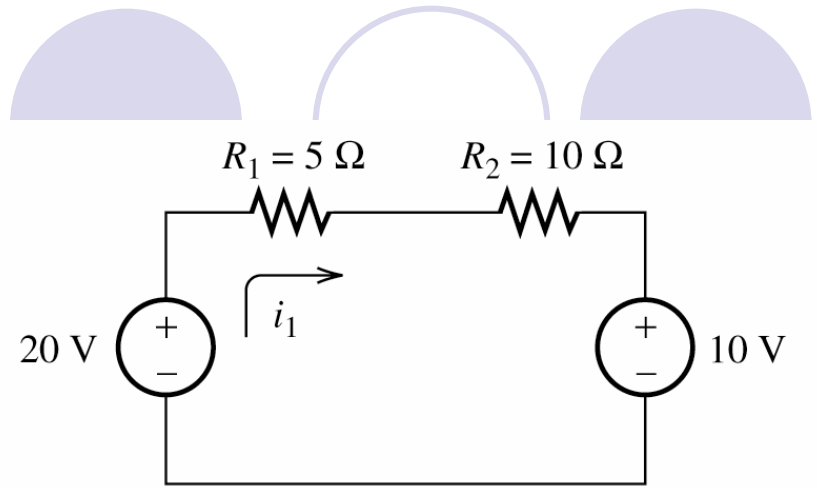

Figure 2.53 A voltage source in series with a resistance is externally equivalent to a current source in parallel with the resistance, provided that $I_n = V_t/R_t$.



(a) Original circuit



(b) Circuit after transforming the current source into a voltage source

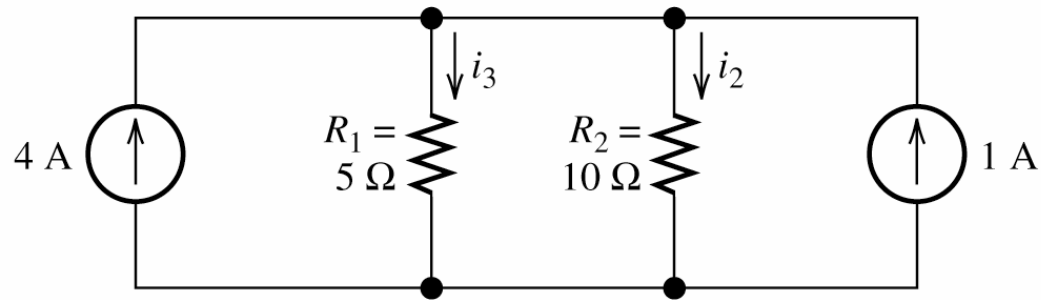

(c) Circuit after transforming the voltage source into a current source

Figure 2.54 Circuit for Example 2.18.

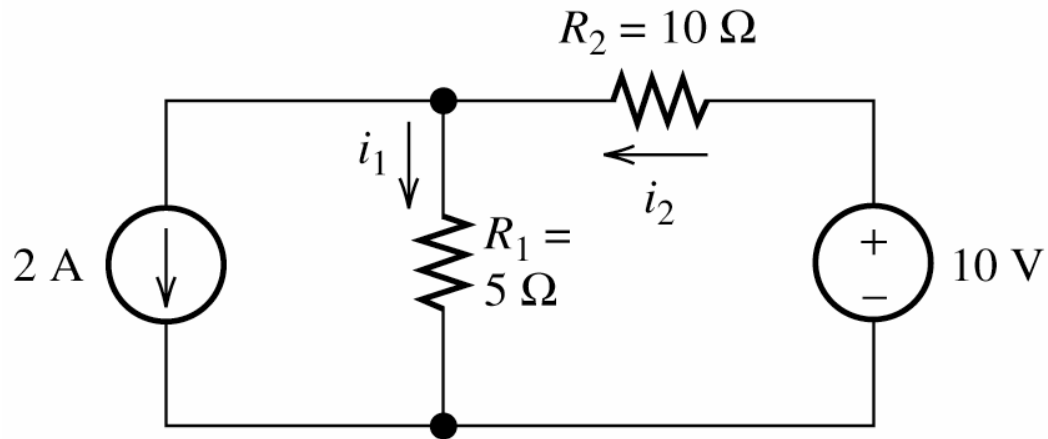
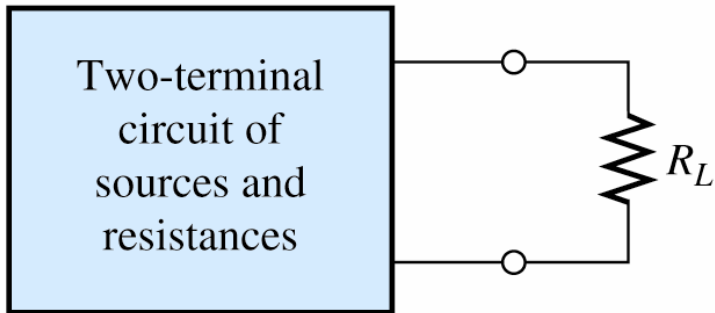
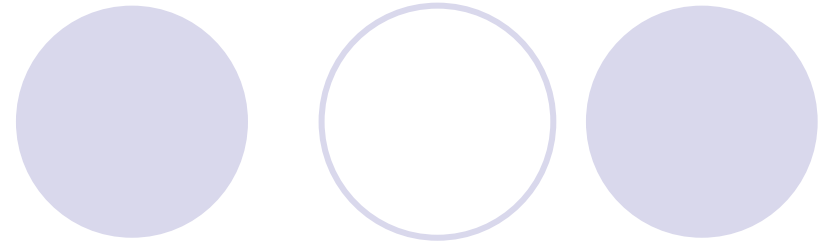
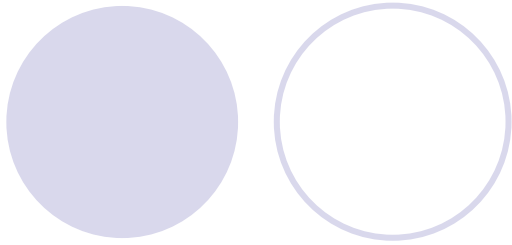

Figure 2.55 Circuit for Exercise 2.26.



Maximum Power Transfer

The load resistance that absorbs the maximum power from a two-terminal circuit is equal to the Thévenin resistance.



(a) Original circuit with load

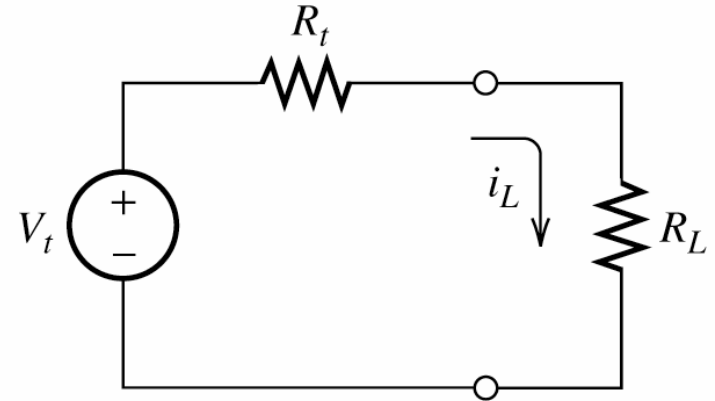

(b) Thévenin equivalent circuit with load

Figure 2.56 Circuits for analysis of maximum power transfer.

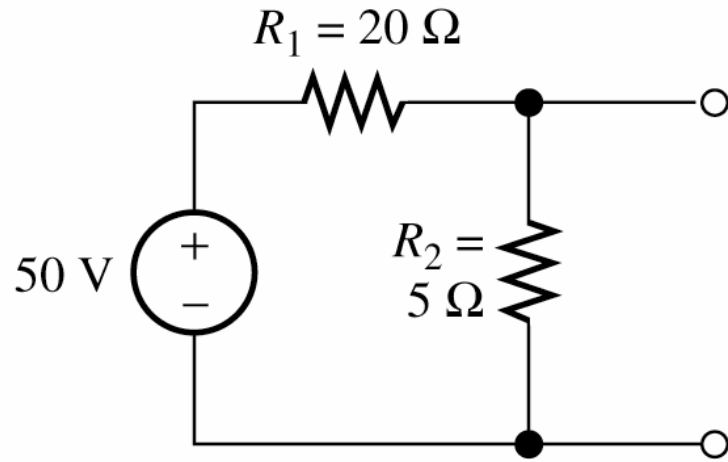

Figure 2.57 Circuit for Example 2.19.

SUPERPOSITION PRINCIPLE



The **superposition principle** states that the total response is the sum of the responses to each of the independent sources acting individually. In equation form, this is

$$r_T = r_1 + r_2 + \cdots + r_n$$

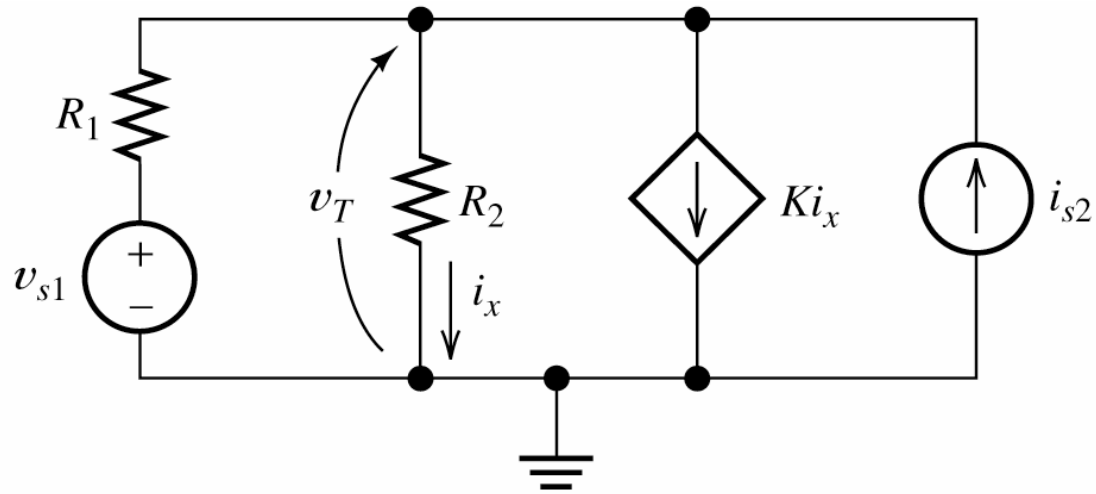
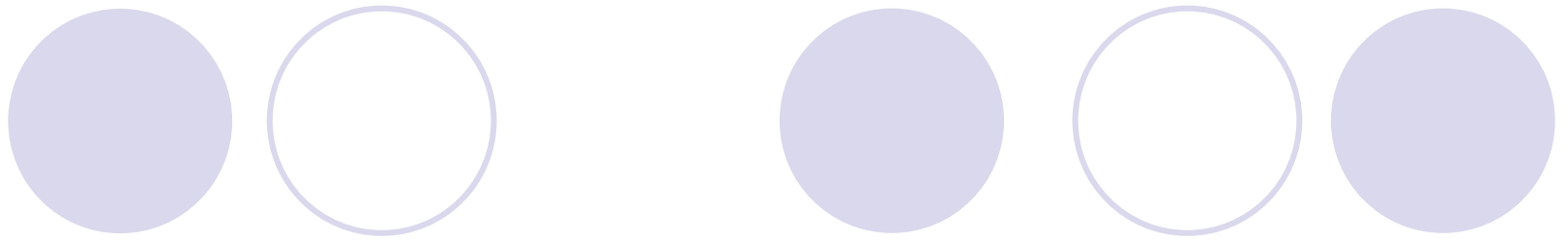

Figure 2.58 Circuit used to illustrate the superposition principle.

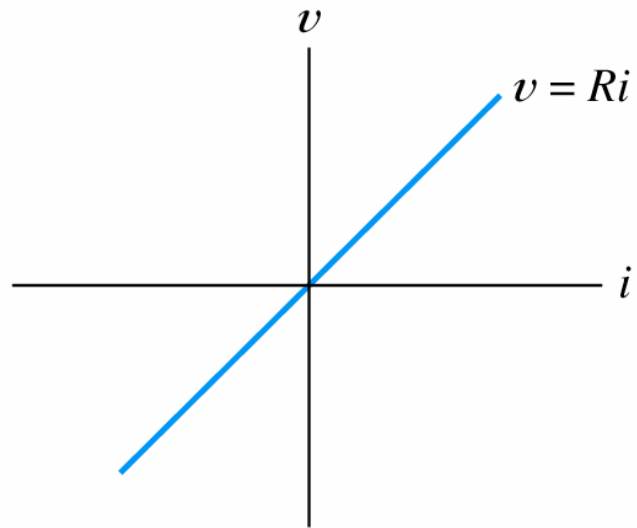
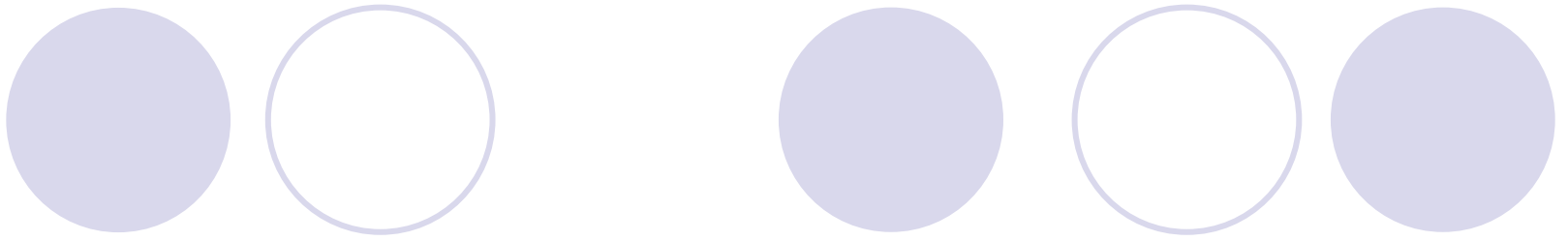
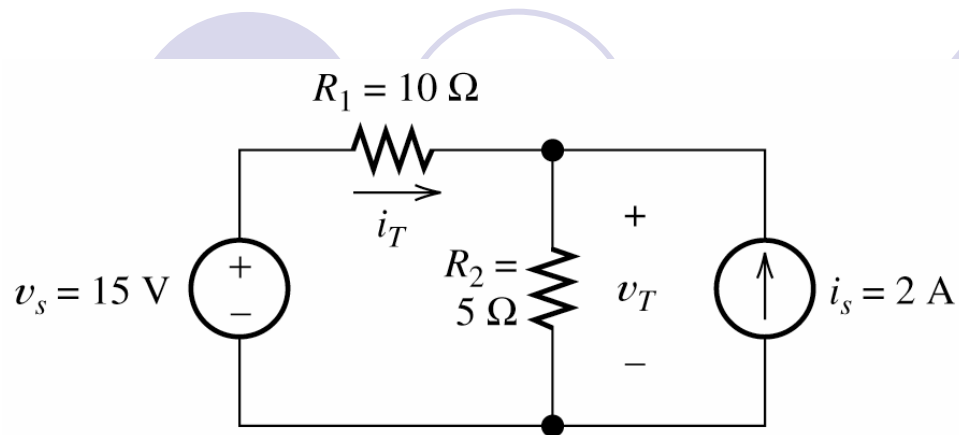
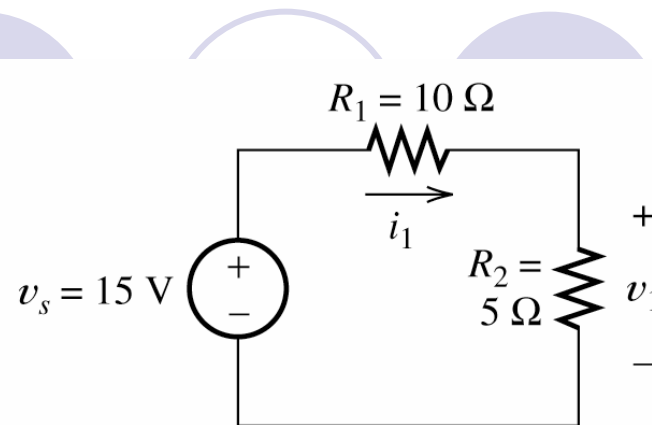

Figure 2.59 A resistance that obeys Ohm's law is linear.



(a) Original circuit



(b) Circuit with only the voltage source active

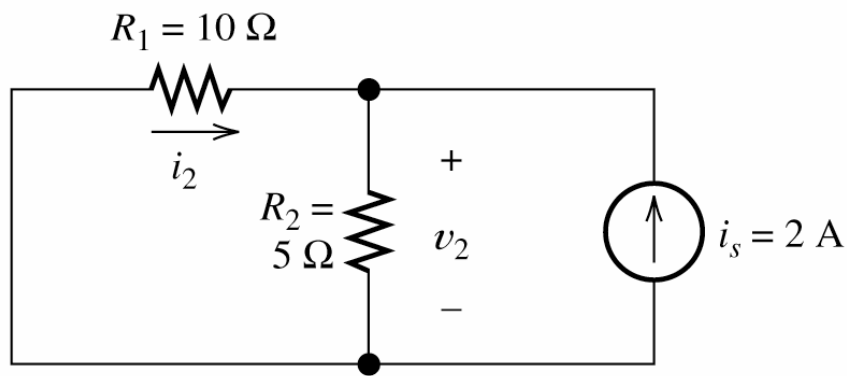

(c) Circuit with only the current source active

Figure 2.60 Circuit for Example 2.20 and Exercise 2.27.

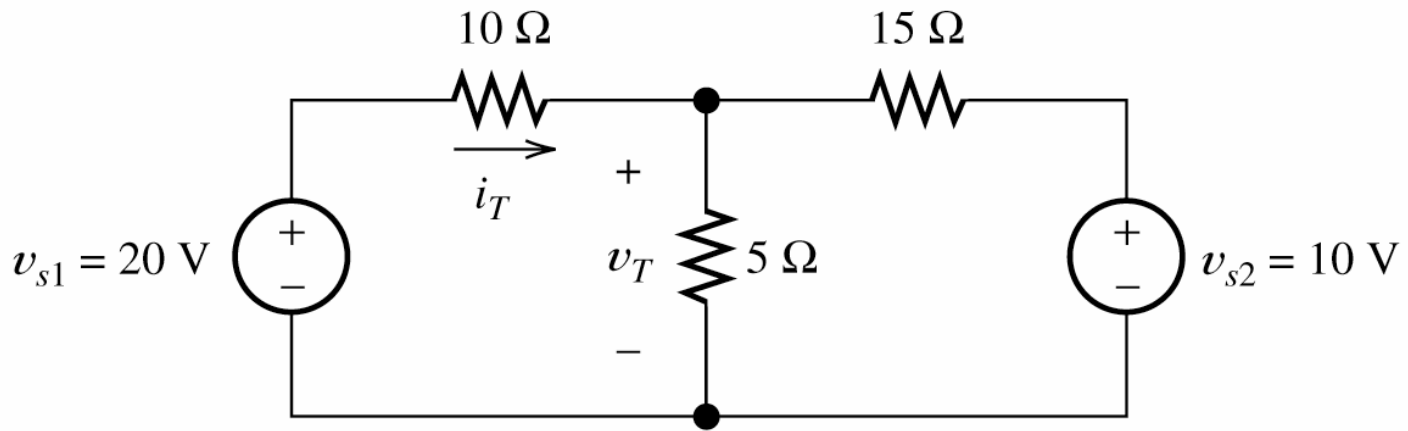
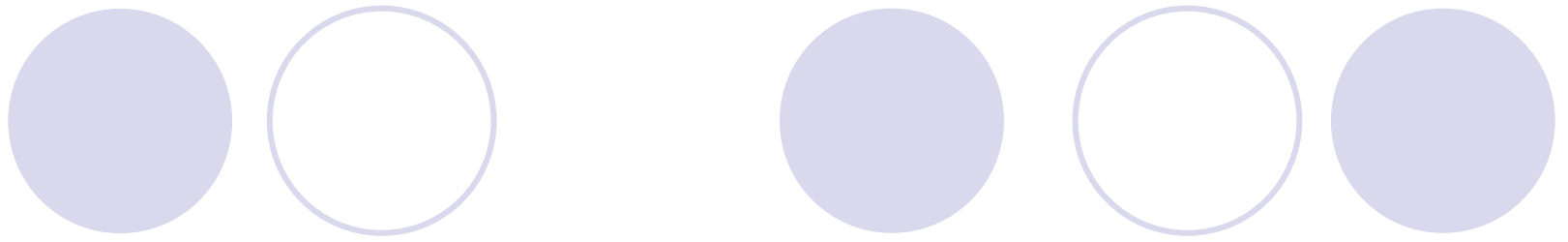

Figure 2.61 Circuit for Exercise 2.28.

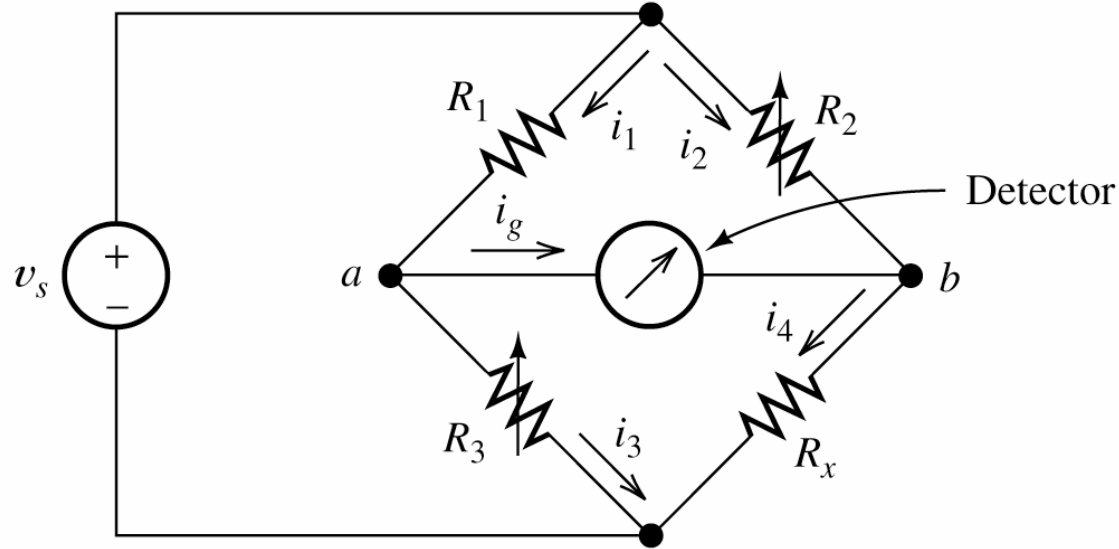
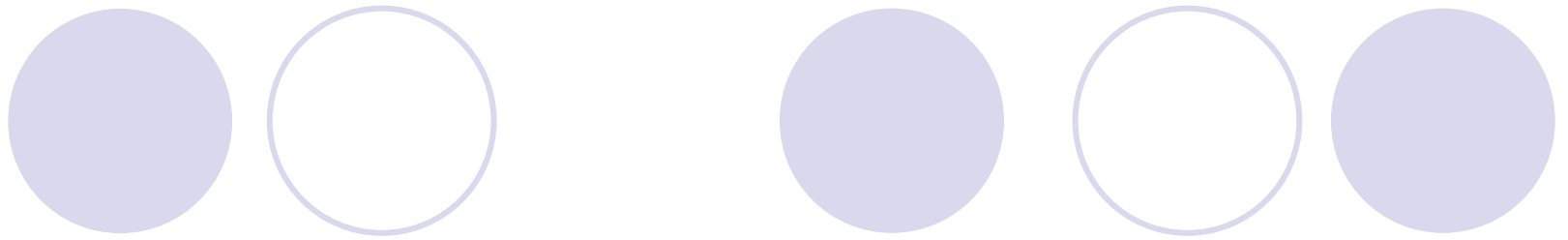
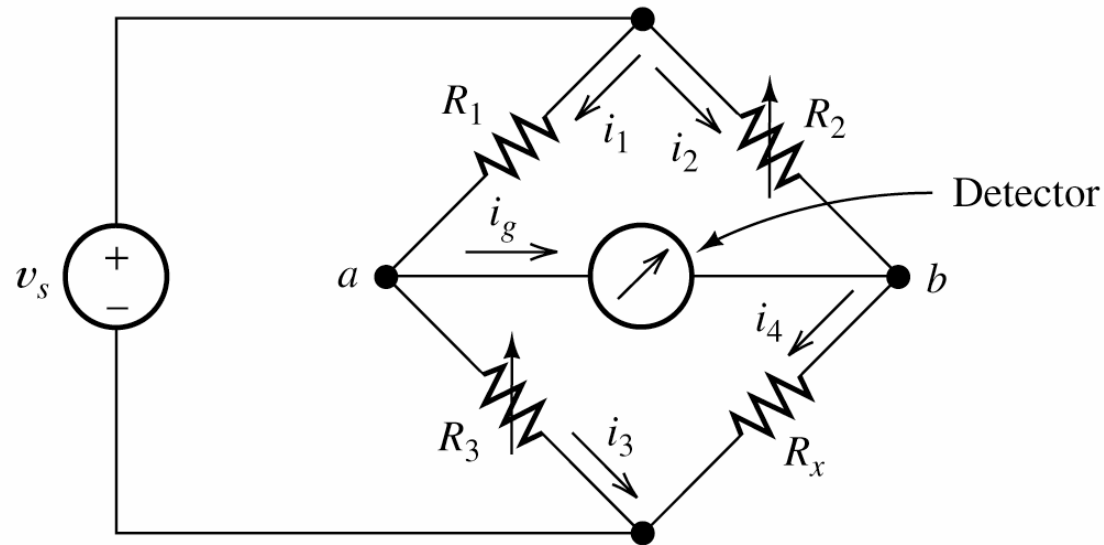

Figure 2.62 The Wheatstone bridge. When the Wheatstone bridge is balanced, $i_g = 0$ and $v_{ab} = 0$.

WHEATSTONE BRIDGE

The Wheatstone bridge is used by mechanical and civil engineers to measure the resistances of strain gauges in experimental stress studies of machines and buildings.

$$R_x = \frac{R_2}{R_1} R_3$$



Problem Set

- 1, 12, 24, 36, 39, 51, 61, 72, 75, 85, 87